

الهيئة السعودية للمواصفات والمقاييس والجودة

Saudi Standards, Metrology and Quality Org. (SASO)



Final Draft Standard

SASO/FDS 31827/2020

School buses - General requirements

ICS: 43.080.20

This document is a draft Saudi Standard circulated for comments. It is, therefore, subject to alteration and modification and may not be referred to as a Saudi Standard until approved by SASO.

Contents

1- Scope.....	3
2- Complementary References	3
3- Terms and definitions	6
4- Classification	7
5- Technical requirements	7
5.1 General.....	8
5.2 Dimensions and weights	8
5.3 Frame and Body.....	8
5.4 Fuel System.....	10
5.5 Seating.....	11
5.6 Alternator	12
5.7 Batteries	12
5.8 Brakes	13
5.9 Exhaust System.....	14
5.10 Sound signaling device	15
5.11 Front bumper.....	15
5.12 Rear bumper.....	15
5.13 Shock absorbers	16
5.14 Drive shaft.....	16
5.15 Engine	16
5.16 Steering System	16
5.17 Tyres and wheels.....	17
5.18 Turning radius.....	17
5.19 Windshield defrosting and defogging systems	18
5.20 Windshield wiping and washing system.....	18
5.21 Front fenders	18
5.22 Service door	18
5.23 Emergency exits.....	20
5.24 Floor covering.....	22
5.25 Insulation.....	23
5.26 Interior.....	23
5.27 Lamps, reflectors, and signals.....	23
5.28 Rearview	26
5.29 Stability.....	27
5.30 Cooling system.....	28
5.31 Safety Belts	28
5.32 Steps.....	28

5.33 Stirrup	29
5.34 Stop signal arm	29
5.35 Crossing arm	30
5.36 Sun shield.....	30
5.37 Undercoating.....	31
5.38 Ventilation.....	31
5.39 Wheel housing	31
5.40 Windshield and windows.....	32
5.41 Electrical components.....	33
5.42 Side intrusion	34
5.43 Speedometer and odometer devises	34
5.44 Controls, telltales and indicators devices.....	35
5.45 Vehicle identification number (VIN).....	36
5.46 Speed limiters.....	36
5.47 Air bags.....	36
5.48 Transmission, starter interlock, and transmission braking effect	36
5.49 Air cleaner.....	37
5.50 Suspension systems.....	37
5.51 Towing attachment points.....	37
5.52 Hinges	37
5.53 Accelerator control.....	37
5.54 Passenger compartment air conditioning.....	38
5.55 Exterior noise level	39
5.56 Limits of gaseous pollutants	39
6- Safety equipments	40
7- Information of vehicle.....	41
8- Owner’s manual (Operating Instructions)	41
9- Identification.....	42
10- School bus requirements for persons with special health care needs.....	43
Annex (A) Roof hatch performance test.....	51
Annex (B) Side Intrusion Test	53
Bibliography	54

School buses - General requirements**1- Scope**

This Standard specifies the technical requirements for school buses intended to transport students to ensuring high levels of safety and environmental protection from gaseous emissions.

2- Complementary References

2.1 SASO GSO 34 "Lead-acid starter batteries used for motor cars and internal combustion engines".

2.2 SASO GSO 35 "Methods of test for lead-acid starter batteries used for motor cars and internal combustion engines".

2.3 SASO GSO 36 "Motor vehicles - Methods of test for impact strength - Part 1: Frontal impact".

2.4 SASO GSO 37 "Motor vehicles - Methods of test for impact strength - Part 2: Moving barrier rear impact".

2.5 SASO/FDS 31843 "School buses - Rear crash test using moving barrier".(FMVSS 571.301)

2.6 SASO GSO 38 "Motor vehicles - Methods of test for impact strength - Part 3A: Side Impact".

2.7 SASO GSO 1707 "Motor vehicles - Methods of test for impact strength - Part 3B: Moving barrier side impact".

2.8SASO/FDS 31832 "School buses - Roof strength".(FMVSS 571.220)

2.9 SASO GSO 40 "Motor vehicles - Impact strength".

2.10 SASO GSO 647 "Multi-purpose vehicles, trucks, buses and trailers tyres - Part 3: General requirements".

2.11 SASO GSO 646 "Multi-purpose vehicles, trucks, buses and trailers tyres - Part 2: Methods of test".

2.12 SASO 469 "Motor vehicles - Dimensions and weights".

2.13 SASO GSO 97 "Motor vehicles - Safety belts".

2.14 SASO GSO 96 "Motor vehicles - Methods of testing safety belts".

2.15 SASO GSO 289 "Road vehicles retro - Reflective number plates and its methods of test".

2.16 SASO GSO 99 "Road vehicles - Sound signaling devices - Technical specification".

2.17 SASO GSO 136 "Motor vehicles - Engine radiator".

2.18 SASO GSO 135 "Motor vehicles - Methods of test for engine radiator".

2.19 SASO GSO 144 "Motor vehicles - Appeasable limits of pollutants emitted to the atmosphere from heavy-duty diesel engine vehicles".

2.20 SASO GSO 145 "Motor vehicles - Methods of testing for pollutants emitted from heavy-duty diesel engine vehicles - Part 1: Determinations of exhaust gaseous pollutants".

2.21 SASO GSO 146 "Motor vehicles - Methods of testing for pollutants emitted from heavy-duty diesel engine vehicles - Part 2: Determination of smoke".

2.22 SASO GSO 1040 "Motor vehicles – Allowable limits of pollutants emitted to the atmosphere from light-duty diesel engine vehicles".

2.23 SASO GSO 1041 "Motor vehicles - Methods of testing for pollutants emitted from light duty diesel engine vehicles - Part 1: Determination of exhaust gaseous pollutants".

- 2.24** SASO GSO 1042 "Motor vehicles - Methods of testing for pollutants emitted from light-duty diesel engine vehicles - Part 2: Determination".
- 2.25** SASO GSO 1680 "Motor vehicles - Allowable limits of gaseous pollutants emitted to the atmosphere from unleaded gasoline engine vehicles".
- 2.26** SASO GSO 1681 "Motor vehicles - Allowable limits of gaseous pollutants emitted to the atmosphere from unleaded gasoline engine vehicles - Part 1: Determination of exhaust gaseous pollutant a cold start".
- 2.27** SASO GSO 1682 "Motor vehicles - Allowable limits of gaseous pollutants emitted to the atmosphere from unleaded gasoline engine vehicles - Part 2: Determination of exhaust carbon monoxide at idle speed".
- 2.28** SASO GSO 1683 "Motor vehicles - Allowable limits of gaseous pollutants emitted to the atmosphere from unleaded gasoline engine vehicles - Part 3: Determination of evaporative emission (hydrocarbons) from the fuel system".
- 2.29** SASO GSO 1684 "Motor vehicles - Allowable limits of gaseous pollutants emitted to the atmosphere from unleaded gasoline engine vehicles - Part 4: Determination of gaseous pollutants emitted from engine crankcase".
- 2.30** SASO GSO 1685 "Motor vehicles - Allowable limits of gaseous pollutants emitted to the atmosphere from unleaded gasoline engine vehicles - Part 5: Determination of durability of pollution control equipment".
- 2.31** SASO GSO 1624 "Motor vehicles - Noise emissions".
- 2.32** SASO GSO 1625 "Motor vehicles - Speed limiters - Part 2: Technical requirements".
- 2.32** SASO GSO 1626 "Motor vehicles - Speed limiters - Part 3: Methods of test".
- 2.33** SASO/FDS 31830 "School buses - School buses - Pedestrian safety devices".(FMVSS 571.131)
- 2.34** SASO/FDS 31834 "School buses - body joint strength".(FMVSS 571.221)
- 2.35** SASO/FDS 31835 "Road vehicles - Speedometer and odometer devices". (ECE 39/2018)
- 2.36** SASO/FDS 31836 "Controls, tell-tales and indicators". (ECE 121:2015 & FMVSS 571.101)
- 2.37** SASO/FDS 31837 "Road vehicles - Windshield defrosting and defogging systems". (FMVSS 571.103)
- 2.38** SASO/FDS 31839 "Road vehicles - Windshield wiping and washing systems". (FMVSS 571.104)
- 2.39** SASO/FDS 31840 "Road vehicles - Transmission shift position sequence, starter interlock and transmission braking effect". (FMVSS 571.102)
- 2.40** SASO/FDS 31841 "Road vehicles - Impact protection for the driver from the steering control system". (FMVSS 571.203)
- 2.41** SASO/FDS 31842 "Road vehicles - Flammability of interior materials". (FMVSS 571.302)
- 2.42** SASO GSO 1677 "Motor vehicles - Laminated safety glass".
- 2.43** SASO ISO 3537 "Road vehicles - Safety glazing materials - Mechanical tests".
- 2.44** SASO ISO 3538 "Road vehicles - Safety glazing materials - Test methods for optical properties".
- 2.45** SASO ISO 3917 "Road vehicles - Safety glazing materials - Test methods for resistance to radiation, high temperature, humidity, fire and simulated weathering".

- 2.46** SASO ISO 13837 "Road vehicles - Safety glazing materials - Method for the determination of solar transmittance".
- 2.47** SASO GSO 1780 "Motor vehicles - Vehicle identification number (VIN) - Requirements".
- 2.48** SASO GSO 1781 "Motor vehicles - Vehicle identification number (VIN) - World manufacturer identifier (WMI)".
- 2.49** SASO GSO 1782 "Motor vehicles - Vehicle identification number (VIN) - Location and attachment".
- 2.50** SASO GSO ISO 3911 "Wheels and rims for pneumatic tyres - Vocabulary, designation and marking".
- 2.51** SASO GSO ISO 3894 "Road vehicles - Wheels/rims for commercial vehicles - Test methods".
- 2.52** SASO GSO ISO 4209-2 "Truck and bus tyres and rims (metric series) - Part 2: Rims".
- 2.53** SASO GSO ISO 1585 "Road vehicles - Engine test code - Net power".
- 2.54** ASTM B117 "Standard Practice for Operating Salt Spray (Fog) Apparatus".
- 2.55** ASTM D750 "Standard Practice for Rubber Deterioration Using Artificial Weathering Apparatus".
- 2.56** ASTM D1894 "Standard Test Method for Static and Kinetic Coefficients of Friction of Plastic Film and Sheeting".
- 2.57** ASTM D2047 "Standard Test Method for Static Coefficient of Friction of Polish-Coated Flooring Surfaces as Measured by the James Machine".
- 2.58** ASTM D4060 "Standard Test Method for Abrasion Resistance of Organic Coatings by the Taber Abraser".
- 2.59** ASTM E308 "Standard Practice for Computing the Colors of Objects by Using the CIE System".
- 2.60** ASTM E810 "Standard Test Method for Coefficient of Retroreflection of Retroreflective Sheeting Utilizing the Coplanar Geometry".
- 2.61** ASTM E1164 "Standard Practice for Obtaining Spectrometric Data for Object-Color Evaluation".
- 2.62** SASO GSO ECE 46 "Uniform provisions concerning the approval of devices for indirect vision and of motor vehicles with regard to the installation of these devices".

3- Terms and definitions

For the purposes of this standard, the following terms and definitions are applied:

3.1 School bus

A specially constructed vehicle that is designed to carry more than ten persons to and from school, university or related events.

3.2 School bus for persons with disabilities

A school bus that is designed to carry persons with disabilities and special health care needs to and from school or related events.

3.3 Gross axle weight rating (GAWR)

The value specified by the vehicle manufacturer as the load- carrying capacity of a single axle system, as measured at the tire-ground interfaces.

3.4 Gross vehicle weight (GVW)

The loaded weight of a single vehicle, as measured at the tire-ground interfaces.

Note: The loaded weight is the sum of the unloaded vehicle weight, rated cargo load, 54 kg times the number of designated seating positions, and 68 kg for the driver.

3.5 Gross vehicle weight rating (GVWR)

The value specified by the vehicle manufacturer as the load- carrying capacity of a single vehicle, as measured at the tire-ground interfaces.

3.6 Curb weight

The weight of a vehicle with standard equipment; maximum capacity of engine fuel, oil, and coolant; and, if so equipped, air conditioning and additional weight optional engine.

3.7 Fixed vehicle structure

A structure that is attached to a vehicle and cannot be removed without tools.

Note: Wheelchairs and wheelchair tie-downs are not considered fixed structures.

3.8 Mobility aid

A device used from persons with disabilities and special health care needs to facilitate transport, in a seated posture.

Note: Examples include manual and powered wheelchairs.

3.9 Person with a disability

A person who, because of a mobility impairment, requires accessible transportation.

4- Classification

4.1 Type A

A conversion or body constructed upon a cutaway front section vehicle with an original equipment manufacturer chassis, supplied with a left side driver's door and service door is behind the front wheels.

4.1.1 Type A1

A vehicle with a GVWR of 4500 kg or less.

4.1.2 Type A2

A vehicle with a GVWR over 4500 kg.

4.2 Type B

A conversion or body constructed and installed upon a van, a front section vehicle chassis, or a stripped vehicle chassis, having a GVWR of more than 4500 kg.

Most of the engine is beneath and/or behind the windshield and beside the driver's seat.

The service door is behind the front wheels.

4.3 Type C

A body installed upon a flat back cowl chassis, having a GVWR of more than 4500 kg.

The entire engine is in front of the windshield and the service door is behind the front wheels.

4.4 Type D

A body installed upon a chassis, having a GVWR of more than 4500 kg. The engine mounted in one of the following positions:

- a) Behind the windshield and beside the driver's seat;
- b) At the back of the bus behind the rear wheels; or
- c) midship between the front and rear axles. The service door is ahead of the front axle.

5- Technical requirements

5.1 General

5.1.1 The effectiveness or integrity of any major safety system (e.g. emergency exit opportunity, fuel system integrity) shall not be compromised.

5.1.2 The safe environment of the bus interior shall not be diminished.

5.1.3 There shall be no additional risk to students during entry or egress or while in near the loading zone.

5.1.4 The new technology, equipment, or components shall result in enhancement in the efficiency and safety of the bus, an enhancement in the safety or experience of the occupants and pedestrians in the vicinity of the bus, or an aid to the performance of the driver's tasks.

5.1.5 The exterior body of school bus shall be yellow according to the color grade number RAL1018ZinkgelbGL841 and no other color interference.

5.1.6 School buses may be equipped with a DAB⁺ and AM/FM/audio and/or public address system having interior and exterior speakers.

5.1.7 School buses shall be equipped with a safety switch at the rear of the bus (inside the bus) to ensure that the bus is clear of passengers before turning off the engine.

5.1.8 Articulated buses and double decker buses shall not be used as school buses.

5.2 Dimensions and weights**5.2.1 Aisles**

5.2.1.1 The minimum width of the aisle between left-side and right-side seats leading to the rear center emergency door or rear center emergency window shall be 350 mm.

5.2.1.2 In the case of Type D bus with the engine inside the front of the body, the minimum distance between any structure (whether fixed or movable) at the rear of the entrance stepwell and the engine cover shall be 300 mm, measured horizontally at any vertical point between the floor level and the height of the top surface of a seat cushion.

5.2.2 Bus length and width

5.2.2.1 The overall length of school bus shall not exceed 12.50 m when measured from bumper to bumper.

Note: Accessories are excluded from this measurement, for more details see the Saudi Standard SASO 496.

5.2.2.2 The outside body width of buses shall not exceed 2.6 m, excluding accessories.

Note: Accessories are excluded from this measurement, for more details see the Saudi Standard SASO 496.

5.2.3 Inside height

5.2.3.1 In the case of Type A1 bus, the inside body height shall be a minimum of 1650 mm measured metal to metal, at any point on the longitudinal centerline from the front vertical bow to the rear vertical bow.

5.2.3.2 In the case of Type A2, B, C, and D buses, the inside body height shall be a minimum of 1800 mm, measured at any point on the longitudinal centerline from the front vertical bow to the rear vertical bow.

Note: The inside height measurement shall not include air conditioning equipment.

5.2.4 Steps height

5.2.4.1 The first step at the service door shall be 250 to 400 mm from the ground.

5.2.4.2 The service door entrance may be equipped with a stepwell that has more than two than two steps.

5.2.4.3 Step risers shall not exceed a height of 250 mm.

Note: The differential may be increased by the thickness of the floor covering used on steel floor.

5.2.5 Seating

5.2.5.1 The minimum width of the seat shall be 400 mm.

5.2.5.2 The minimum depth of a seat shall be 380 mm.

5.2.5.3 The minimum seat back height shall be 610 mm above the seating reference point.

5.2.5.4 The minimum seat height shall be 350 mm from the ground.

5.2.5.5 The minimum between the back seats shall be 650 mm.

5.2.6 Weights

5.2.6.1 All school buses shall not exceed the maximum allowable gross vehicles weight (GVW) and gross axle weight (GAW) according to SASO 469.

5.3 Frame and Body**5.3.1 Frame**

5.3.1.1 At a minimum, the frame or equivalent shall have design and strength characteristics that correspond to those that are standard for trucks with the same general load characteristics and that are used for highway service.

5.3.1.2 Holes in the top or bottom flanges of the frame side rail shall not be permitted (other than those provided in the original chassis frame).

5.3.1.3 Frames shall not be modified for the purpose of extending the wheel base.

5.3.1.4 When frame side members are used in Type B, C, and D buses, they shall be a one-piece construction between the front hanger brackets of the front spring and the rear hanger brackets of the rear spring.

5.3.2 Body

5.3.2.1 General

5.3.2.1.1 All openings between the chassis and passenger compartment shall be sealed to prevent exhaust gases from leaking into the passenger compartment.

5.3.2.1.2 The floor shall have an overlay of 13 mm covering with a surface suitable for foot traffic

The overlay shall be securely fastened to the floor and have the following performance characteristics:

- a) A minimum bearing strength of 4.5 MPa; and
- b) A minimum R value of 0.58.

5.3.2.1.3 The aisle shall be on the same level as the bus floor.

5.3.2.1.4 The external surface of a school bus shall be free from any prominent sharp or rotating parts that could cause road traffic risk.

5.3.2.1.5 The chassis frame shall extend to the rear edge of the rear body cross-member. Except where chassis components interfere, the body of the bus shall be attached to the chassis frame at each main floor sill in a manner that prevents shifting or separation of the body from the chassis under severe operating condition.

5.3.2.1.6 In the case of a Type C bus, the body front shall be attached and sealed to the chassis cowl in a manner that prevents entry of water, dust, and fumes through the joint between the chassis cowl and the body.

5.3.2.1.7 Each school bus shall be provided with places at the front and rear of the school bus for fixing the number plates according to dimensions specified in Saudi Standard SASO GSO 289.

5.3.2.2 In addition to meeting the requirements of Clauses 5.3.2.1.1 to 5.3.2.1.3, the construction of the body of every Type A2, B, C, and D bus shall meet the following requirements:

5.3.2.2.1 The floor shall be constructed of steel at least 14 gauge or equivalent.

5.3.2.2.2 All metal except high-grade stainless steel or aluminum used in construction of the bus body shall be zinc-coated or aluminum-coated or treated to prevent corrosion (includes structural members, inside and outside panels, door panels and floor sills).

5.3.2.2.3 The metal so treated shall include parts such as structural member, inside and outside panels, floor panels, and floor sills, and shall exclude door handles, grab handles, stanchions, interior decorative parts, and other interior plated parts.

5.3.2.2.4 In addition to meeting the requirements of Clauses 5.3.2.2.2 and 5.3.2.2.3, all metal parts to be painted shall be:

- a) Chemically cleaned, etched, zinc phosphate coated, and zinc chromate or epoxy primed (includes crossing control arm and stop arm); or
- b) Conditioned by an equivalent process.

5.3.2.2.5 In fulfilling the requirements of Clauses 5.3.2.2.2 to 5.3.2.2.4, particular attention shall be given to:

- a) Lapped surfaces;
- b) Welded connections of structural members;
- c) Cut edges;
- b) Punched or drilled hole areas in sheet metal;
- e) Closed or box sections;
- f) Unvented or undrained areas; and
- g) Surface subjected to abrasion during vehicle operation.

5.3.2.2.6 As evidence that the requirements of Clauses 5.3.2.2.2 to 5.3.2.2.4, have been met, samples of materials and section used in construction of the bus body, when subjected to the 1000 h salt spray test in accordance with ASTM B117, shall not lose more than 10% of the material by weight.

5.3.2.2.7 Each body panel joint (including small, curved, and complex joints) shall meet the technical requirements and test procedures according to **SASO/FDS 31834 “School buses - body joint strength”**.

5.3.2.1.8 The whole design and construction of school buses, shall withstand the impact forces to the front, rear, side and roof to reduce the likelihood of injuries to the driver and passengers, as follows:

- a) All school buses with a gross vehicle weight (GVW) of 4500 or less according to Saudi Standard SASO GSO 40 when tested in accordance with SASO GSO 36”
- b) All school buses with a gross vehicle weight (GVW) of 4500 kg or less according to Saudi Standard SASO GSO 40 when tested in accordance with SASO GSO 37
- c) All school buses with a gross vehicle weight (GVW) over 4500 kg according to Standard **SASO/FDS 31843 “School buses - Rear crash test using moving barrier”**
- d) All school buses with a gross vehicle weight (GVW) of 4500 kg or less according to Saudi Standard SASO GSO 40 when tested in accordance with SASO GSO 38.
- e) All school buses with a gross vehicle weight (GVW) of 4500 kg or less according to Saudi Standard SASO GSO 40 when tested in accordance with SASO GSO 1707.
- f) All school buses when tested in accordance with **SASO/FDS 31832 “School buses - Roof strength”**.

5.4 Fuel System

5.4.1 The fuel tank and its connections shall be securely placed and installed in a manner that will become resist exposure to damage from vibration, impact, or flammability.

5.4.2 Each fuel tank fill pipe shall be provided with a securely closed cap at the pipe inlet.

5.4.3 The design of the fuel tank position and its connections shall be such that no fuel leaks occur when the bus is subjected to an impact test, as following:

- a) All school buses with a gross vehicle weight (GVW) of 4500 or less according to Saudi Standard SASO GSO 40 when tested in accordance with SASO GSO 36
- b) All school buses with a gross vehicle weight (GVW) of 4500 kg or less according to Saudi Standard SASO GSO 40 when tested in accordance with SASO GSO 37

c) All school buses with a gross vehicle weight (GVW) over 4500 kg according to Standard SASO/FDS 31843 “School buses - Rear crash test using moving barrier”

5.4.4 In the case of Type C buses, the fuel tank, fittings, or fuel lines between the fuel tank and the engine shall not extend above the chassis frame rail on the portion of the chassis that is behind the cowl.

5.4.5 The fuel fill hose assembly for all buses shall be entirely isolated from the passenger compartment to prevent fumes or fuel from penetrating the passenger compartment and to protect any exposed components of the fuel fill hose assembly from damage.

5.4.6 Fuel tank having a minimum 94-liter capacity shall be provided by the chassis manufacturer.

5.5 Seating

5.5.1 Driver Seat

5.5.1.1 The driver’s seat supplied by the body manufacturer shall be a high back seat.

5.5.1.2 The seat back shall be adjustable to 15 degrees minimum, without requiring the use of tools.

5.5.1.3 The seat shall be equipped with a head restraint.

Note: Type A buses may utilize the standard driver’s seat provided by the chassis manufacturer.

5.5.2 Passenger Seating

5.5.2.1 School bus design capacities shall meet the technical requirements according to Standard⁽¹⁾.

5.5.2.2 Each seat leg shall be secured to the floor by bolts, washers and nuts and flange-head nuts may be used in lieu of nuts and washers.

5.5.2.3 All seat frames attached to the seat rail shall be fastened with two or more bolts, washers and nuts, or with flange head nuts.

5.5.2.4 All school buses shall be equipped with restraining barriers.

5.5.2.5 A flip-up seat may be installed at any side emergency door and shall be free of sharp projections on the underside of the seat bottom and shall be padded or contoured to reduce the possibility of clothing being snagged.

5.5.2.6 A flip-up seats shall be constructed to prevent passenger limbs from becoming entrapped between the seat back and the seat cushion when the seat is in the upright position.

5.5.2.7 The seat cushion shall be designed to rise to a vertical position automatically when it is not occupied.

5.5.3 Covering material

5.2.3.1 All seat and restraining barrier covering shall be made of material that is of at least 1.2 kg finished weight, is at least 1370 mm wide, and has a finished vinyl coating of 1.06 broken twill when tested using the following test methods (CFFA-1A; CFFA-3; CFFA-6A; CFFA-10; CFFA-16C; and CFFA-17) according to Chemical Fabrics and Film Associations Standard

Note: Material of equivalent or better quality may be used.

5.2.3.2 In the case of Type B, C, and D buses, the driver’s seat shall have vertical and before and after adjustment of at least 100 mm.

⁽¹⁾ Follow the standard 49 CFR 571.222 until the Saudi standard is adopted

5.2.3.3 In the case of Type B, C, and D buses, the driver's seat shall be mounted to allow it to be adjusted in such a way that it can be positioned from 280 to 381 mm from the rearward most point of the steering wheel under the following conditions:

- a) With the seat centered in its vertical travel;
- b) With the seat back, if adjustable, in a vertical position; and
- c) With the steering wheel centered in its travel for tilt and /or telescope positions, as applicable.

5.5.4 Supervising seats

5.5.4.1 The school bus shall be equipped with at least one seat for supervisor when the number of seats is 20 passengers or less.

5.5.4.2 The school bus shall be equipped with at least two seats for supervisor when the number of seats is more than 20 passengers.

5.5.4.3 The supervisor's seat shall be located in the direction of the students on the aisle of the bus and close to the passenger door.

5.5.4.4 When there is more than one of the supervisory seats, there shall be at least one of the supervisory seats close to the emergency door.

5.5.4.5 The Supervision seats shall be provided with a three-point safety belt.

5.5.4.6 Supervising seats must be marked.

5.5.4.7 Supervision seats may be foldable.

5.6 Alternator

5.6.1 All Type A and B buses with a GVWR of 6800 kg or less shall have a minimum 130 A alternator.

Buses equipped with an electrically powered wheelchair lift and/or air conditioning shall be equipped with an alternator of the highest rated capacity available from the chassis original equipment manufacturer.

5.6.2 All buses over 6800 kg GVWR shall be equipped with a heavy-duty truck or bus type alternator having a minimum output rating of 200 A or higher, and the alternator should produce a minimum current output of 50% of the rating at engine idle speed.

5.6.3 All buses over 6800 kg GVWR equipped with an electrically powered wheelchair lift and/or air conditioning shall have a minimum alternator output of 240 A and may be equipped with a device that advances the engine idle speed when the voltage drops to, or below, a pre-set level.

5.6.4 A belt-driven alternator shall be capable of handling the rated capacity of the alternator with no detrimental effect on any other driven components.

5.6.5 A direct/gear-drive alternator is permissible in lieu of a belt-driven alternator.

5.7 Batteries

5.7.1 The batteries of school bus shall meet the engine starting and other electrical load requirements.

5.7.2 The manufacturer shall securely attach the battery on a slide-out or swingout tray in a closed, vented compartment outside the passenger compartment at the body skirt or chassis frame so that the battery is accessible for convenient servicing from the outside or cut off the electrical supply in case of an impact.

5.7.3 When in the stored position, the tray shall be retained by a securing mechanism capable of holding the tray in position when subjected to a 5g load from any direction

5.7.4 The battery compartment door or cover, if separate from the tray, shall be hinged at the front or top.

5.7.5 The door may be an integral part of the battery slide tray.

5.7.6 The door or cover shall fit tightly to the body, and not present sharp edges or snagging points.

5.7.7 Any chassis frame-mounted batteries shall be relocated to a battery compartment on Type A buses.

5.7.8 In all cases the battery cable provided with the chassis shall have sufficient length to allow some slack, and shall be of sufficient gauge to carry the required amperage.

5.7.9 All school buses provided with 6 V and 12 V lead-acid batteries shall meet the technical requirements according to Saudi Standard SASO GSO 34 when tested in accordance SASO GSO 35.

5.8 Brakes

5.8.1 General

5.8.1.1 Each school bus shall be equipped with service brake system adequate to control the movement of, and to halt it safely, speedily and effectively whatever its speed and load, on any up or down gradient.

5.8.1.2 The braking system provided on the school bus shall be suitable for it and ensure safe braking performance under normal and emergency conditions.

5.8.1.3 The effectiveness of the brake system shall be checked by measuring the stopping distance.

5.8.1.4 Any material affecting public health shall not be used in the brake system directly or after its interaction with other elements such as asbestos and cadmium.

5.8.1.5 The control of the service brake device shall be independent of the control of the parking braking device.

5.8.1.6 The driver shall control the service brake pedal by his right foot.

5.8.1.7 All buses shall have either a parking pawl in the transmission or a park brake interlock that requires the service brake to be applied to allow release of the parking brake.

5.8.1.8 Each brake drum or rotor shall be permanently marked with a legible cast or stamped legend that clearly indicates the maximum safe inside diameter (in the case of the drum) or minimum safe thickness (in the case of the rotor) beyond which it should not be used.

5.8.1.9 The brake lines, booster-assist lines, and control cables shall be protected from excessive heat, vibration and corrosion and installed so that they are protected from chafing.

5.8.1.10 All brake systems of school buses shall be designed to permit visual inspection of brake lining wear without removal of any chassis component other than inspection covers and dust covers.

5.8.1.11 All school buses shall be provided with Anti-lock braking system (ABS) according to Standard⁽²⁾.

⁽²⁾ Follow the standard 49 CFR 571.105 & 49 CFR 571.121 or ECE 13 until the Saudi standard is adopted

5.8.1.12 The parking brake system for either air or hydraulic service brake systems may be of a power-assisted design.

5.8.1.13 The power parking brake actuator shall be a device located on the instrument panel within reach of a driver.

5.8.1.14 The power-operated parking brake system may be interlocked to the engine key switch. Once the parking brake has been set and the ignition switch turned to the "off" position, the parking brake cannot be released until the key switch is turned back to the "on" position.

5.8.2 Hydraulic and electric brake systems

5.8.2.1 All school buses equipped with a hydraulic and electric service brake systems and parking brake systems shall meet the technical requirements according to Standard⁽³⁾.

5.8.3 Air brake systems

5.8.3.1 All school buses equipped with air brake systems shall meet the technical requirements according to Standard⁽⁴⁾.

5.8.3.2 The air pressure supply system shall include a desiccant-type air dryer installed according to the manufacturer's recommendations and the air pressure storage tank system may incorporate an automatic drain valve.

5.8.3.3 The chassis manufacturer shall provide an accessory outlet for air-operated systems installed by the body manufacturer and this outlet shall include a pressure protection valve to prevent loss of air pressure in the service brake reservoir

5.8.3.4 An air pressure gauge shall be provided in the instrument panel.

5.8.3.5 Air brake systems shall include a system for anti-compounding of the service brakes and parking brakes.

5.8.3.6 Air brakes shall have both a visible and audible warning device whenever the air pressure falls below the level.

5.9 Exhaust system

5.9.1 General

5.9.1.1 The exhaust gases shall not be allowed into the passenger compartment, which affects passenger health.

5.9.1.2 The exhaust pipe, muffler, and tailpipe shall be located outside the passengers' compartment and attached to the chassis so any other chassis component is not damaged, except that the last tailpipe hanger may be attached to the body.

5.9.1.3 Adequate clearance or heat protection shall be provided between the exhaust system and the fuel tanks, fuel lines, flexible brake lines and hose, or other flammable material to prevent ignition and/or heat deterioration.

5.9.2 Type A buses

5.9.2.1 The engine exhaust system shall meet the original equipment manufacturer's specifications.

5.9.2.2 In no case shall any portion of exhaust be discharged directly beneath a wheelchair lift, emergency exit door, or a gasoline or diesel fuel fill opening.

⁽³⁾ Follow the standard 49 CFR 571.105 or ECE 13 until the Saudi standard is adopted.

⁽⁴⁾ Follow the standard 49 CFR 571.121 or ECE 13 until the Saudi standard is adopted

5.9.3 Type B, C, and D buses

In addition to being in accordance with Clause 5.9.1, the exhaust systems shall comply with the following Clause:

5.9.3.1 The tailpipe shall be constructed of a corrosion resistant tubing material at least equal in strength and durability to 16-gauge steel tubing of equal diameter.

5.9.3.2 The engine exhaust system shall meet the original equipment manufacturer's specifications.

5.9.3.3 The exhaust system tailpipe shall terminate flush with or no more than 50 mm beyond the rear bumper.

5.9.3.4 In no case shall any exhaust be discharged directly beneath a wheelchair lift, emergency exit door, or a gasoline or diesel fuel fill opening.

5.10 Sound signaling device

5.10.1 All school buses shall be equipped with a sound signaling device (horn) capable of emitting a continuous, uniform sound and its acoustic spectrum shall not vary substantially during its operation that meet the technical requirements of Saudi Standard SASO GSO 99.

5.10.2 All school buses shall be equipped with an audible alarm that will operate automatically when the bus is traveling to the back, making a sound heard sufficiently to alarm pedestrians and other vehicles in the back, and the sound level shall be from 87 to 120 dBA.

5.11 Front bumper

5.11.1 All school buses shall be provided a front bumper.

5.11.2 The bumper shall extend beyond the forward-most part of the body, grille, hood and fenders and shall extend to the outer edges of the fenders at the bumper's top line to ensure maximum fender and body protection.

5.11.3 The front bumper shall be strong enough to push another vehicle of equally rated GVW on level ground without causing permanent distortion to the bumper, chassis, or body.

5.11.4 The front bumper on buses of Type A-2 (with GVWR greater than 6600 kg), Type B, Type C, and Type D shall be equivalent in strength and durability to pressed steel channel at least 5 mm thick and not less than 200 mm wide (high).

5.11.5 If the front bumper is used for lifting, the contact points shall be under the bumper attachments to the frame rail brackets unless the manufacturer specifies different lifting points in the owner's manual.

5.11.6 The front bumper shall be of sufficient strength to permit being pushed by another vehicle on a smooth surface with a 5-degree, (8.7 percent) grade, without permanent distortion.

5.11.7 The bumper shall be designed or reinforced so that it will not deform when the bus is lifted by a chain that is passed under the bumper (or through the bumper if holes are provided for this purpose) and attached to both tow hooks/eyes.

5.12 Rear bumper

5.12.1 All school buses shall be provided a rear bumper and shall be attached directly to the chassis frame in a manner that prevents hitching or riding thereon, and with provisions for easy removal.

5.12.2 The rear bumper shall be of sufficient strength to permit the bus to be pushed at rated GVW on level ground by another vehicle without causing permanent distortion to the bus.

5.12.3 The rear bumper shall be constructed and attached to the bus in a manner that develops the full strength of the bumper section upon rear or side impact.

5.12.4 The rear bumper shall extend beyond the rear-most part of the body surface at least 25 mm, measured at the floor line.

5.12.5 In addition to meeting the requirements specified in Clause 5.12.1 to 5.12.4, the rear bumper on Type A2, B, C, and D buses shall meet the following requirements:

a) it shall be of pressed steel channel or an equivalent material at least 5 mm thick and 240 mm high;

b) it shall be wrapped around the back corners of the bus; and

c) it shall extend forward at least 300 mm, measured from the rear-most point of the body at the floor line, and shall be mounted flush with the sides of the body or protected with an end panel.

5.12.6 The rear bumper on Type A-1 buses shall be a minimum of 200 mm wide (high).

5.12.7 The bottom of the rear bumper shall not be more than 760 mm above ground level.

5.13 Shock absorbers

The school bus shall be equipped with front and rear double-acting shock absorbers that compatible with the manufacturer GAWR.

5.14 Drive shaft

The drive shaft shall be protected by a metal guard around the circumference of the drive shaft to reduce the possibility of its whipping through the floor or floor or dropping to the ground if broken.

5.15 Engine

5.15.1 The engine shall be suitable for the type of fuel used domestically, either unleaded gasoline or diesel oil specially with respect to Sulphur contents and the deterioration effect on the accessories equipped with exhaust emission controls.

5.15.2 The engine and its accessories shall be suitable for use in in dusty weather conditions and high ambient temperatures especially as concerns the radiator (type and size), air filter, engine block cooling system, thermostat and battery.

5.15.3 The on-board diagnostic (OBD) system (Stage One) shall be suitable to enable it to identify the types of deterioration or malfunction over the entire life of the bus.

5.15.4 The GVWR of any school bus shall not exceed 84.0 kg per certified net published horsepower of the engine at rated speed.

5.15.5 Method of engine speed testing to evaluate their performance shall be according to Saudi Standard SASO GSO ISO 1585.

5.16 Steering System

5.16.1 The steering system shall be such as to be easily and securely handled by the driver in his normal driving position.

5.16.2 The steering wheel shall be on the left side.

5.16.3 Changes shall not be made to the steering apparatus unless approved by the chassis manufacturer.

5.16.4 There shall be a clearance of at least 50 mm between the steering wheel rim and the cowl, instrument panel, windshield, or any other surface.

5.16.5 For buses equipped with adjustable steering wheels, a clearance of less than 50 mm shall be permitted during driver entry and egress from the seat; however, the steering wheel shall be designed to permit a minimum clearance of 50 mm during operation of the bus.

5.16.6 The steering system shall be designed to provide a means for lubrication of all wear points that are not permanently lubricated.

5.16.7 When the steering control system (for school buses with a gross vehicle weight (GVW) of 4500 or less) is impacted by a body block at a relative velocity of 24 km/h., the impact force on the chest of the body block transmitted to the steering control system shall not exceed 11,120 N according to **SASO/FDS 31841 “Road vehicles - Impact protection for the driver from the steering control system”** (FMVSS 571.203).

5.16.8 When a school bus with a gross vehicle weight rating (GVWR) of 4,500 kg or less is tested according to SASO GSO 36 at 48 km/h perpendicular impact into a fixed collision barrier, the upper end of the steering column and shaft in the vehicle shall not be displaced more than 127 mm in a horizontal rearward direction parallel to the longitudinal axis of the vehicle as shown in Saudi Standard SASO GSO 40. (FMVSS 571.204)

5.17 Tyres and wheels

5.17.1 All tyre on a school bus, including the spare if provided, shall be of the same size.

5.17.2 The school bus shall be equipped with a spare tyre and suitably mounted in an accessible location outside the passenger compartment.

5.17.3 All Tyre shall meet the technical requirements according to Saudi Standard SASO GSO 647 when tested in accordance SASO GSO 646.

5.17.4 School buses tyres shall be provided with speed symbol (M) (130 km/h) and higher rating tyres.

5.17.5 All school busses shall be provided with a Tyre Pressure Monitoring System (TPMS) which informs the driver when a tyre is below the vehicle manufacturers recommended running pressure except those school busses with dual rear wheels on an axle, and shall comply with the technical requirements of Standard⁽⁵⁾.

5.17.6 Dual rear wheels shall be provided on Type A2, B, C, and D buses.

5.17.7 All wheels and rims shall meet technical requirements in accordance with Saudi Standard SASO GSO ISO 3894, SASO GSO ISO 3911 and SASO GSO ISO 4209-2.

5.18 Turning radius

5.18.1 Chassis with a wheelbase of 6700 mm or less shall have a left- and right-turning radius of not more than 13.0 m curb-to-curb measurement.

5.18.2 Chassis with a wheelbase greater than 6700 mm shall have a left- and right-turning radius of not more than 13.5 m curb-to-curb measurement.

⁽⁵⁾ Follow the standard 49 CFR 571.138 or ECE 141 until the Saudi standard is adopted.

5.19 Windshield defrosting and defogging systems

5.19.1 The Defrosting and defogging equipment shall direct a sufficient flow of heated air onto the windshield, the window to the left of the driver and the glass in the viewing area directly to the right of the driver to eliminate frost and fog.

5.19.2 The defroster and defogging system shall be capable of furnishing heated, outside ambient air, except that the part of the system furnishing additional air to the windshield, entrance door and stepwell may be the re-circulating air type.

5.19.3 Auxiliary fans are not considered defrosting or defogging systems.

5.19.4 Portable heaters shall not be used.

5.19.5 The defroster system shall meet the performance requirements of **Standard SASO/FDS 31837 " Road vehicles - Windshield defrosting and defogging systems"**

5.20 Windshield wiping and washing system

5.20.1 Each school bus shall be provided with a power-driven windshield wiping system that meet the technical requirements of **Standard SASO/FDS 31839 "Road vehicles - Windshield wiping and washing systems"**.(FMVSS 571.104)

5.20.2 Each windshield wiping system shall have at least two frequencies or speeds.

5.20.3 One frequency or speed shall be at least 45 cycles per minute regardless of engine load and engine speed.

5.20.4 The lower frequency or speed shall be at least 20 cycles per minute regardless of engine speed and engine load.

5.20.5 The highest and one lower frequency or speed shall differ by at least 15 cycles per minute.

5.20.6 Each school bus shall be provided with a windshield washing system that meets the technical requirements of **Standard SASO/FDS 31839 "Road vehicles - Windshield wiping and washing systems"**.(FMVSS 571.104)

5.21 Front fenders

5.21.1 The width of the front fenders measured from their outer edges along the fender line shall exceed the total spread of the front tires when the front wheels are in the straight-ahead position.

5.21.2 Front fenders shall be properly braced and shall not require attachment to any part of the body.

5.22 Service door**5.22.1 General**

5.22.1.1 The service door shall be on the right side of the bus, within direct view of the driver.

5.22.1.2 The service door shall be operated electronically, and shall be provided with a manual means to facilitate its opening from the inside during an emergency.

5.22.1.3 The service door shall be designed so that the driver in his seat can control the opening or closing.

5.22.1.4 The service door shall be designed so as to afford easy release but prevent accidental opening.

5.22.1.5 The service door shall be of the split or bifold type, and shall open outward.

5.22.1.6 The vertical closing edges of the split or bifold type service door shall be equipped with flexible material to minimize the possibility of injury.

5.22.1.7 Service door openings shall be padded at the top interior edge, and padding shall be at least 75 mm wide, at least 25 mm thick, and extend the full width of the door opening.

5.22.1.8 If the service door is equipped with a security lock, the handle shall be incapable of being moved from the locked to unlocked position (or vice versa) without use of a key.

5.22.1.9 Manual door controls shall not require more than 9 kg of force to operate at any point throughout the range of operation, as tested on a 10% grade, both uphill and downhill.

5.22.1.10 All service door glass shall be approved safety glass.

5.22.1.11 The bottom of each lower glass panel shall be not more than 254 mm from the top surface of the bottom step.

5.22.1.12 The top of each upper glass panel when viewed from the interior shall be not more than 76 mm below the interior door control cover or header pad.

5.22.1.13 If Type A bus with a separate entrance door for the driver is equipped with a security lock on the service door, the bus shall be equipped with a device that prevents the engine from starting when the service door lock is engaged.

Note: When a hand lever is used, no parts shall come together in a manner that could shear or crush fingers.

5.22.2 Service door emergency release

5.22.2.1 The service door shall be equipped with manual emergency release mechanism that can be operated from the exterior of the bus.

5.22.2.2 Power-operated doors shall be equipped with an emergency override operated from the interior in case power failure.

5.22.2.3 If the exterior emergency release mechanism is equipped with a lock, the bus shall be equipped with a device that prevents the engine from starting when the lock is enabled.

5.22.2.4 The words "SERVICE DOOR EMERGENCY RELEASE" in Arabic and English, in black lettering, shall be displayed adjacent to the manual emergency release device required by Clause 5.22.2.1 and 5.22.2.2.

The lettering shall comply with the following requirements:

- a) it shall be at least 25 mm high;
- b) the stroke width of the lettering shall be at least 4 mm; or 1/6 of the height of letters; and
- c) exterior lettering shall have a yellow background.

5.22.3 Type A buses

5.22.3.1 In addition to meeting the requirements of Clauses 5.22.1 and 5.22.2, the entrance shall have a minimum horizontal opening width of not less than 584 mm and a minimum vertical opening of 1727 mm.

5.22.4 Type B, C, and D buses

5.22.4.1 In addition to meeting the requirements of Clauses 5.22.1 and 5.22.2, the service doors shall meet the following requirements:

- a) The service door shall have a minimum horizontal opening of 610 mm and a minimum vertical opening of 1727 mm.

- b)** The upper and lower door panels shall contain double hermetically sealed safety glass.
- c)** The bottom of the lower glass panels shall be located not more than 900 mm from the ground when the bus is unloaded.
- d)** The top of the upper glass panel shall be located not more than 152 mm from the top of the door.

Note: An equivalent product may be used if it meets the performance characteristics of hermetically sealed safety glass.

5.22.5 Handrail

5.22.5.1 A handrail shall be provided on the left and right sides of the service door entrance and meet the following requirements:

- a)** it shall be securely mounted on the inside of the body and shall extend down to a location not more than 813 mm above the ground;
- b)** its top shall be a minimum of 711 mm above the level of the passenger compartment floor;
- c)** It shall be made from 25 ± 7 mm outside diameter circular cross-section material and be constructed from corrosion resistant material; and
- d)** It shall be designed to prevent entanglement.

5.22.5.2 If a second handrail is installed on the dashboard side of the service entrance, the following requirements shall be met:

- a)** It shall meet the requirements of Clause 5.22.5.1, except that the height of the handrail may be reduced to provide clearance at the door control; and
- b)** The horizontal opening of the service entrance shall meet the minimum width requirements of Clauses 5.22.3 and 5.22.4.1(a).

5.23 Emergency exits

5.23.1 General

5.23.1.1 All school buses shall be equipped with emergency exits.

5.23.1.2 Any installed emergency exit shall comply with the design and performance requirements according to Standard⁽⁶⁾.

5.23.1.3 Each emergency door, roof hatch, or window above the rear divan seat shall be designed to be opened from the inside and outside of the bus.

5.23.1.4 Provision for opening from the outside shall consist of a non-detachable device designed to prevent hitching but to permit opening when necessary.

5.23.1.5 Each emergency exits shall be equipped with a device that prevents operation of the bus if the is locked.

5.23.2 Emergency doors

5.23.2.1 The rear emergency door shall be equipped with a device to prevent it from swinging beyond the body side line.

5.23.2.2 Each emergency exit door shall be equipped with a positive door-opening device so that:

- a) Bear the hinged weight of the door;
- b) Maintains the door in an open position at a minimum of 90 degree from the bus body; and
- c) Provides a means for release or override.

Note: The positive door-opening device shall meet the requirements of Items a) and b) without the need for action beyond opening the door past the 90-degree minimum from the bus body.

5.23.2.3 No exterior device that can be used as a hitch or handle for riding shall be installed on the door.

5.23.2.4 The upper portion of each emergency exit door shall be equipped with safety glazing material, having an exposed area of not less than 2580 cm².

5.23.2.5 The lower portion of the rear emergency door shall be equipped with safety glazing material having an exposed area of not less than 2260 cm².

5.23.2.6 Padding at the top of the door opening shall be at least 75 wide and at least 25 mm thick, and extend the full width of the door opening.

5.23.2.7 There shall be no steps leading to the emergency door.

5.23.2.8 There shall be no obstruction higher than 6 mm across the bottom of any emergency door opening.

5.23.2.9 Fasteners used within the emergency exit opening shall be free of sharp edges or burrs.

5.23.2.10 Seats or other fixed objects shall be placed in the bus in such a way that when measured from the rear emergency exit door, the aisle shall allow an opening, at minimum:

- a) 608 mm wide × 304 mm deep × 1140 mm high for Type A1 buses;
- b) 608 mm wide × 608 mm deep × 1140 mm high for Type A2, B, C, and D buses.

5.23.2.11 Emergency doors shall be equipped with a locking mechanism designed to as a security (Vandal) lock, and the lock shall prevent the operation of the bus while lock engaged.

⁽⁶⁾ Follow the standard 49 CFR 571.217 until the Saudi standard is adopted.

5.23.2.12 All emergency exit doors shall be accessible by a 300 mm minimum aisle.

5.23.2.13 A flip seat in the unoccupied (up) position shall not obstruct the 300 mm minimum aisle to any side emergency exit door.

5.23.3 Roof hatches

5.23.3.1 At least one roof hatch, centered approximately side-to-side and front-to-back of the passenger compartment, shall be provided in all school buses.

5.23.3.2 Where two or more roof hatches are provided, they shall be centered side-to-side and approximately equally spaced front-to-back in the passenger compartment.

5.23.3.3 The roof hatch and the surroundings of the roof hatch frame shall not permit the passage of a sphere with a diameter of 100 mm when it is pressed through any opening by a force of 22 N, including the weight of the sphere, when tested in accordance with Annex (A).

5.23.4 Rear windows

5.23.4.1 If the school bus is equipped with a window emergency exit above the rear divan seat, the area between the top of the seat and the lower edge of the window shall be capable of supporting a 90 kg mass over any 26 cm² area.

5.23.4.2 The rear emergency window shall have a lifting assistance device that will aid in lifting and holding the rear emergency window open.

5.23.5 Side windows

5.23.5.1 General

A school bus equipped with emergency exit side windows shall have an even number of such windows, evenly divided between the right and left sides of the bus, and these windows shall be approximately equally spaced along both sides of the bus.

Note:

- 1) The location of the emergency exit side windows takes priority over the location of LATCH seats.
- 2) prohibit LATCH seats from being located beside an emergency exit side window.

5.23.5.2 No side emergency exit window will be located above a stop arm.

5.23.5.3 Type A2, B, C, and D buses

5.23.5.3.1 Each side of the school bus shall have at least one hinged emergency exit side window, preferably located mid- bus.

5.23.5.3.2 For school buses with a capacity of 37 passengers or more, each side of the bus shall have at least two hinged emergency exit side windows.

5.23.6 Number and types of emergency exits

The use of the following tables is to determine the required number and types of emergency exits, based on the bus seating capacity as following:

- a) Use Table (1) if the bus contains a rear emergency door, or
- b) Use Table (2) if the bus contains a rear pushout emergency window AND a left side emergency door.

Available combinations by capacity	Manufacturers equipped capacity	Roof hatches	Side emergency exit windows (left)	Side emergency exit windows (Right)	Side emergency exit door (left)
1 - 45	1 - 45	1	0	0	0
46 - 77	46 - 77	2	1	1	0
	46 - 77	2	0	0	1
78 - 93	78 - 93	2	2	2	0
	78 - 93	2	1	1	1

Table (1) – School buses with rear emergency door
(All front engine buses)

Available combinations by capacity	Manufacturers equipped capacity	Roof hatches	Side emergency exit windows (Left)	Side emergency exit windows (Right)	Side emergency exit door (Right)
1 - 45	1 - 45	1	0	0	0
46 - 89	46 - 89	2	1	1	0
	46 - 89	2	0	0	1
90 - 105	90 - 105	2	2	2	0
	90 - 105	2	1	1	1

Table (2) – School buses with rear pushout window and left side emergency door
(All rear engine buses)

5.24 Floor covering

5.24.1 The floor covering in the under seat area (including the wheel housing), the driver’s compartment, the toe board area, the aisle, and the entranceways shall have a minimum overall thickness of 3.18 mm.

Note: For Type A and B buses, the floor covering in the driver’s compartment and toe board area shall meet the original equipment manufacturer’s specification.

5.24.2 The floor covering in the under seat area (including the wheel housing), the driver’s compartment, the toe board area, the aisle, and the entranceways shall have a burn rate of 0.1 mm per minute or less calculated using the test methods, procedures, and formulas **specified in SASO/FDS 31842 “Road vehicles - Flammability of interior materials”**. (FMVSS 571.302)

5.24.2 The floor covering in the aisle and entrance areas shall be slip resistant and have a minimum coefficient of friction of 0.6 when tested in accordance with ASTM D2047 or 0.85 when tested in accordance with SASO GSO ASTM D1894.

5.24.3 The floor covering shall not crack when subjected to sudden temperature change.

5.24.4 The floor covering shall be securely bonded to the floor with a waterproof material recommended by the manufacturer of the floor covering material, exception of the driver's area.

5.24.5 All seams shall be heat welded or sealed with a waterproof sealer.

5.25 Insulation

5.25.1 The ceiling and walls of the bus shall be insulated with materials to deaden sound and vibration and reduce heat transfer and shall meet the flammability requirements in **Standard SASO/FDS 31842 "Road vehicles - Flammability of interior materials"**. (FMVSS 571.302)

5.25.2 All insulating materials used for the reduction of heat transfer shall have an "R" value of at least 5.5.

5.25.3 A formed-in-place type of insulation shall be of equivalent performance.

5.26 Interior

5.26.1 The interior of the bus shall be free of all unnecessary projections (include luggage racks and attendant handrails) to minimize the potential for injury.

5.26.2 Overhead luggage racks shall be prohibited.

5.26.3 There shall be an inner lining on the ceiling and walls.

5.26.4 If the inner lining contains lapped joints, the forward lining panel shall be lapped by the rear lining panel, and exposed edges shall be beaded, hemmed, flanged, or otherwise treated to minimize sharp edges.

5.26.5 A means of securement shall be provided for cleaning equipment installed in suitable position that does not impede passenger safety or driver visibility.

5.26.6 The securement device shall be designed to retain the equipment (e.g. a broom or mop).

5.26.7 A waste receptacle, with a removable insert, shall be securely installed so as not to create a tripping hazard or impede passenger entry or exit, and the location shall be forward of the front barrier, maintain the minimum aisle width, and not impede driver visibility.

5.27 Lamps, reflectors, and signals

5.27.1 Turn-signals and stop/tail lamps

5.27.1.1 Each school bus shall be equipped with rear turn-signal lamps.

5.27.1.2 The rear turn-signal lamps shall be illuminated in amber color.

5.27.1.3 The rear turn-signal lamps shall be not less than 178 mm in diameter or if a shape other than round, a minimum 245 cm² of illuminated area.

5.27.1.4 Turn-signal lamps shall be connected to the chassis hazard warning switch so that they will flash when needed as a vehicular traffic hazard warning.

5.27.1.5 Turn signal lamps are to be placed as wide apart as practical and their horizontal centerline shall be a maximum of 300 mm below the rear window.

5.27.1.6 Each school bus shall be equipped with amber side-mounted turn signal lamps.

5.27.1.7 The side turn signal lamp on the left side shall be mounted rearward of the stop signal arm and the side turn signal lamp on the right side shall be mounted rearward of the entrance door.

5.27.1.8 Each school bus shall be equipped with four combination stop/tail lamps as following:
a) Two combination lamps with a minimum diameter of 178 mm in diameter or if a shape other than round, a minimum 245 cm² of illuminated area shall be mounted on the rear of the bus just inside the turn signal lamps.

b) Two combination lamps with a minimum diameter of 100 mm, or if a shape other than round, a minimum of 77 cm² of illuminated area, shall be placed on the rear of the body between the beltline and the floor line.

5.27.1.9 The stop/tail lamps shall be illuminated in red color.

5.27.1.10 The rear license plate lamp may be combined with one lower tail lamp.

5.27.1.11 Stop lamps shall be activated by the service brakes and shall emit a steady light when illuminated.

5.27.1.12 The two stop lamps shall be installed at the same elevation as the turn signal on the rear of the bus.

5.27.2 Alternating flashing warning lamps

5.27.2.1 All school buses shall be equipped with two red at the rear of the bus and two red lamps at the front of the bus.

5.27.2.2 In addition to the four red lamps described above, four amber lamps shall be installed so that one amber lamp is located near each red signal lamp, at the same level, but closer to the vertical centerline of the bus.

The system of red and amber signal lamps shall be wired so that amber lamps are energized manually.

5.27.2.3 The alternating flashing warning lamps shall meet test procedure and performance requirements according to Standard⁽⁷⁾.

5.27.2.4 The eight alternating flashing lamps shall be installed in accordance with Standard⁽⁷⁾, except that each amber warning lamp shall be located near each red warning lamp, at the same level but closer to the vertical centerline of the bus.

5.27.2.5 The alternating flashing system shall be controlled so that:

a) The amber alternating flashing lamps are activated by a momentary switch that can operated only manually by the driver's hand or foot:

b) when the amber alternating flashing lamps are activated and the bus service door is opened,

i) The amber warning lamps are automatically deactivated;

ii) The red alternating flashing lamps are automatically deactivated; and

iii) The stop arm and the crossing arm are extended;

c) when the service door is opened, the red alternating flashing lamps and stop arm do not activate if the momentary switch has not first been activated (sequential mode); and

d) The red alternating flashing lamps are deactivated, and the stop arm and safety crossing arm are retracted, when the following:

i) The service door is closed; or

ii) The bus starts to move forward.

⁽⁷⁾ Follow the standard SAE J887 until the Saudi standard is adopted.

5.27.2.6 Unless the bus is equipped with a driver-controlled override switch that capable of deactivating the warning light system at any point during its operation, a master control switch that energizes the system shall be provided and shall be labelled or color coded.

5.27.2.7 An amber and red pilot lamp system shall be provided to alert the as to which warning lamp system is activated, and shall be located so that the pilot lamps are readily visible to the seated driver.

5.27.2.8 The alternating flashing lamps switch and pilot lamps shall be located forward of the driver, between the left A pillar and approximately the center of the bus.

5.27.2.9 The area around the lens of each alternately flashing warning lamps, extending outward 25 mm to 125 mm, shall be black.

5.27.3 Floor-level side maker lamps

5.27.3.1 The rear side maker lamps shall be located on all Type A2, B, C, and D buses.

5.27.3.2 The rear side maker lamps shall be located no more than 150 mm above or below the floor line and horizontally no more than 150 mm forward or rearward of the location of the upper side marker lamp.

5.27.3.3 The rear side marker lamps shall be equipped with a reflective-type red lens.

5.27.4 Interior lamps

Interior lamps shall be provided to illuminate the aisle and entrance areas adequately.

5.27.5 Exterior lamps

Tail lamps, side marker lamps, clearance lamps, and identification lamps shall be activated with the daytime running lamp (DRL) system.

Note: All exterior lighting should be LED except head/park/turn combination assemblies.

5.27.6 Strobe lamps

5.27.6.1 An optional white flashing strobe lamp may be installed on the roof of a school bus at a location not to exceed the body length forward from the rear of the roof edge.

5.27.6.2 If the bus is equipped with a roof hatch or other roof mounted equipment falling within the above-mentioned measurements, the strobe lamp may be located directly behind that equipment.

5.27.6.3 The lamp shall have a single clear lens emitting light 360 degrees around its vertical axis.

Note: When utilizing LED strobe lamps, minimum specifications shall be in compliance with Standard⁽⁸⁾.

5.27.6.4 Strobe lamp shall have a switch lighted in the ON position or an interior indicator lamp that is visible to the driver.

5.27.7 Exit lamps

The school bus shall be equipped with an exterior lamp will illuminate the area on the right side of the bus at the most forward point on the front bumper to the centerline of the rear axle, and it shall include the following:

- a) Project white light;
- b) Allow operation of the lamp system when the alternating flashing warning lamps are activated.

⁽⁸⁾ Follow the standard SAE J845 Class 2 requirements until the Saudi standard is adopted.

- c) With the service door and windows closed, shall produce a minimum illumination of 10 lux when measured at each point on the grid on a vertical surface at 0.5 m and 1.0 m above the ground;
- d) 10 lux at the vertical outside surface of the bus measured at the outer surface of the bus and outward at 1.0 m and 2.0 m and from the most forward point of the front bumper at intervals of every 1-meter proceeding toward the centerline of the rear axle;
- e) Have a minimum light in a manner that prevents light from shining directly into the right-side rear-view mirror and crossover mirror;
- f) Turn on when the door is opened; and
- g) Turn off approximately 5 s after the door has closed.

5.27.8 Backup lamps

5.27.8.1 The school bus body shall be equipped with two white rear backup lamps that are at least 100 mm in diameter or, if a shape other than round, a minimum of 77 cm² of illuminated area.

5.27.8.2 If backup lamps are placed on the same horizontal line as the brake lamps and turn signal lamps, they shall be to the inside.

5.27.9 Exterior lamps for emergency exits

5.27.9.1 Type A1, A2, B, C, and D (front engine) buses

The backup lamps or landing area lamps shall be illuminated when the rear emergency door is unlatched.

5.27.9.2 Type D (rear engine) buses

All Type D school buses that are equipped with a rear engine shall be equipped with a backup lamp or a landing area that illuminates when the rear emergency window is unlatched.

5.27.9.3 Side emergency door exits

All school buses that are equipped with a side emergency door shall be equipped with a landing area lamp that illuminates when the side emergency door is opened.

5.27.9.4 Continuous power to backup and landing area lamps

Backup and landing area lamps shall operate with the ignition key in any position (i.e., there shall be continuous power to the lamp).

5.27.10 All school buses equipped with a monitor for the front and rear lamps of the school bus, the monitor shall be mounted in full view of the driver.

If the full circuit current passes through the monitor, each circuit shall be protected against any short circuit or intermittent shorts by a fuse circuit breaker, or electronic protection device.

5.28 Rearview

5.28.1 General

5.28.1.1 All school bus shall be equipped with an indirect vision device to observe the traffic area adjacent to the vehicle which cannot be observed by direct vision.

5.28.1.2 Indirect vision devices can be conventional mirrors, camera-monitors or other devices able to present information about the indirect field of vision to the driver.

5.28.2 Mirrors

5.28.2.1 Each school bus shall be equipped with one internal rear-view mirror and two external rear-view mirrors.

5.28.2.2 All mirrors shall be firmly fixed so that they do not move too much leading to a change in the field of view and thus cause a misinterpretation of the driver to realize what he observes when the bus is traveling at high speed.

5.28.2.3 All mirrors shall be adjustable type and mounted in a position to allow the driver in his seat to have a clear view of the traffic of other vehicles on both sides.

5.28.2.4 All mirrors shall be of unit magnification, if the mirror is a flat mirror;

5.28.2.5 All mirrors shall be free of sharp points or edges that could injure an occupant of the bus or a pedestrian.

5.28.2.6 All mirrors shall be installed at a location where the blind spot created by the mirror is minimized.

5.28.3 Exterior rear-view mirrors

5.28.3.1 Each school bus shall have two outside rear-view mirror systems, called System A and System B, and shall comply with Standard⁽⁹⁾.

5.28.3.2 System A mirrors shall be remote controlled along the horizontal and vertical axis, and the remote-control actuator shall be located within reach of the seated driver position.

5.28.4 Interior rear-view mirrors

5.28.4.1 General

- a) Interior rear-view mirrors shall have rounded corners and padded edges;
- b) Interior rear-view mirrors shall be designed to reduce danger of injury upon impact;
- c) Interior rear-view mirrors shall be made of safety glass; and
- d) Interior rear-view mirrors shall afford the driver a view of the bus interior.

5.28.4.2 Type A1 and A2 buses

In addition to meeting the requirements of Clause 5.28.4.1, the interior rear-view mirrors shall be at least 150 mm high and 400 mm wide.

5.28.4.3 Type B, C, and D buses

In addition to meeting the requirements of Clause 5.28.4.1, the interior rear-view mirrors shall be at least 150 mm high and 760 mm wide.

5.28.5 Rear-view camera

Each school bus shall be equipped with a rear-view camera that helps the driver to see clearly to avoid the risk of accidents while the bus is traveling backward, and it is in accordance with Saudi Standard SASO GSO ECE 46.

5.29 Stability

5.29.1 Any school bus shall not overturn when tilting it is unladen and laden state to the left or right side at an angle of (35°) or the stability of the bus overturn is the point at which the overturning occurs and should be limited to lateral acceleration.

5.29.2 All school buses shall be provided with an Electronic Stability Control (ESC).

⁽⁹⁾ Follow the standard 49 CFR 571.111 until the Saudi standard is adopted.

5.30 Cooling system

5.30.1 Each school bus shall be equipped with a cooling system suitable for the climate of the Kingdom of Saudi Arabia to keep the engine at the most efficient operating temperature at all engine speeds and under all driving conditions.

5.30.2 Cooling system in which the liquid is used shall be provided with a tool (thermostat) that reduces the ineffective or cold operating time of the engine.

5.30.3 The radiator and cooling fans shall be large enough to reduce the operating temperature of the engine to be below the maximum allowable.

5.30.4 All school buses equipped with a radiator which was use water as a cooling medium shall meet the technical requirements according to Saudi Standard SASO GSO 136 when tested in accordance SASO GSO 135.

5.31 Safety Belts**5.31.1 Seat belt for driver**

5.31.1.1 The driver shall be provided with a three-point safety belt and shall meet the technical requirements according to Saudi Standard SASO GSO 97 when tested in accordance SASO GSO 96.

5.31.1.2 The safety belt shall be designed to allow only one person to use it at one time.

5.31.1.3 The safety assembly belt does not cause any injury to its user when the collision occurs.

5.31.1.4 On buses where the driver's seat and upper anchorage for the shoulder belt are both attached to the body structure, a driver's seat with an integrated lap/shoulder belt may be substituted.

5.31.1.5 On buses where the driver's seat and upper anchorage for the shoulder belt are separately attached to both body and chassis structures (i.e., one attached to the chassis and the other attached to the body), a driver's seat with an integrated lap/shoulder belt should be used.

5.31.1.6 The lap/shoulder belt shall be designed to allow for easy adjustment in order to fit properly and to effectively protect drivers varying in size.

5.31.1.7 Each school bus shall be equipped with a durable webbing cutter having a full width handgrip and a protected, replaceable or non-corrodible blade.

5.31.1.8 The required webbing cutter shall be mounted in a location accessible to the seated driver in an easily detachable manner.

5.32 Steps**5.32.1 Type B, C, and D buses**

In addition to meeting the requirements of Clause 5.2.4, the step shall meet the following requirements:

5.32.1.1 Steps shall not protrude beyond side body line.

5.32.1.2 The floor line platform area and all steps shall comply with the following requirements:
a) They shall be covered with, at a minimum overall thickness of 5 mm elastomer treads backed with metal or with an additional 5 mm elastomer.

The treads shall have at least 38 mm white or yellow nosing, or shall have a 75 mm white elastomer edge, backed with metal or with an additional 5 mm of elastomer, at the floor line platform.

- b) The backing of the tread shall be, at a minimum, 24 gauge cold-rolled steel or a 5 mm durable backing and shall be permanently bonded to the textured raised elastomer.
- c) The design of the surface shall be grooved in such a way that grooved run at 90 angles to the long dimension of the step tread or shall be pebbled, with a minimum pebble height of 3.2 mm.
- d) The 5 mm textured step tread shall have 38 mm white or yellow nosing as an integral piece without a joint.
- e) The elastomer portion of the tread shall have the following characteristics:
 - i) abrasion resistance: special compounding for abrasion resistance shall ensure that the step tread material weight loss does not exceed 0.4% when tested in accordance with ASTM D4060 (CS-17 Wheel, 1000-gram, 1000 cycle).
 - ii) weathering resistance: step treads shall not break, crack, or check after ozone exposure of (7 days at 50 pphm at 40 degrees C) and weather meter exposure in accordance with ASTM D750; and
 - iii) flame resistance: step treads shall have a burn rate of 0.01 mm per minute or less calculated using the test methods, procedures, and formulas specified in SASO/FDS 31842 “Road vehicles - Flammability of interior materials”. (FMVSS 571.302)

5.32.1.3 The material shall be applied not only to the interior surfaces of the service door step treads but also to the exterior, if not covered by undercoating.

5.32.1.4 The stepwell shall be illuminated by at least one lamp providing white light, actuated automatically by the opening of the door.

5.33 Stirrup (Type C and D buses)

In addition to meeting the requirements of Clauses 5.2.4 and 5.32.1, steps shall also meet the following requirements:

5.33.1 There shall be one folding stirrup step and a suitable located handle to permit easy accessibility for cleaning the windshield and lamps.

In the case Type D buses, steps in or on the front bumper may be used in lieu of stirrup steps.

5.33.2 The design of the stirrup step shall not allow any article to become entangled in the step when passengers are entering or exiting the bus.

5.34 Stop signal arm

5.34.1 Each school bus shall be equipped with a stop signal arm as depicted in Figure (1).

5.34.2 The stop signal arm shall be installed on the left side of the bus.

5.34.3 The stop signal arm shall be automatically extended with the passenger door open.

5.34.4 Stop signal arm assemblies shall meet the technical requirements and test procedures according to SASO/FDS 31830 “School buses - Pedestrian safety devices”. (FMVSS 571.131)

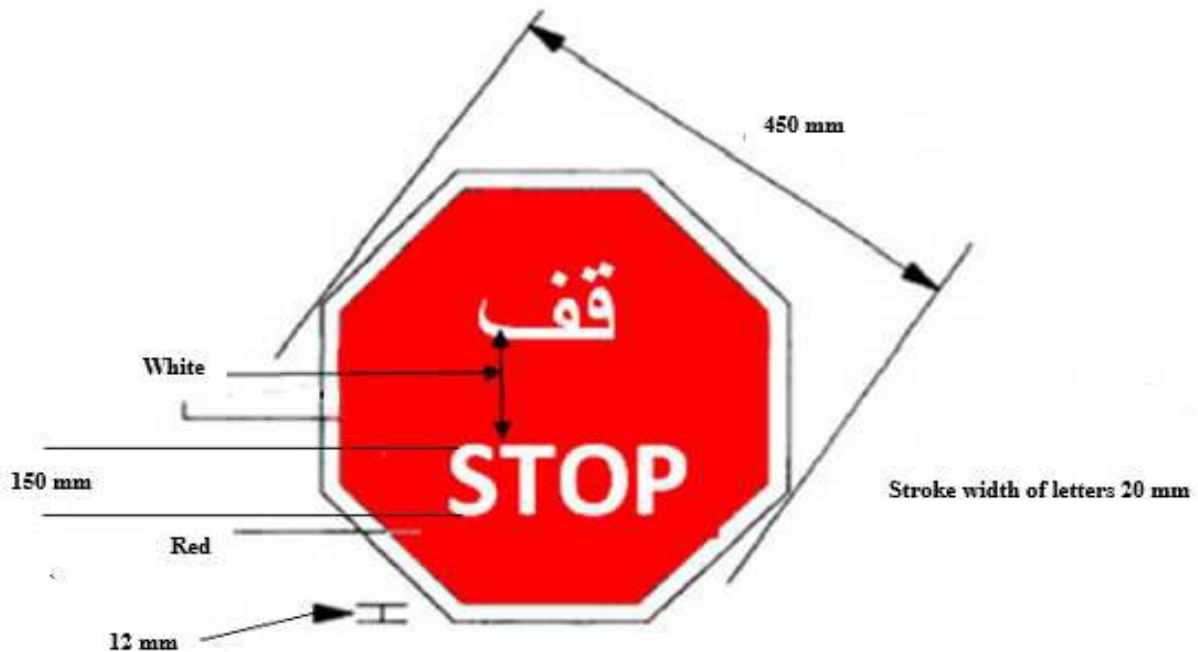

Figure (1) - characteristic of stop signal device

5.35 Crossing arm

5.35.1 School buses shall be equipped with a pedestrian-student safety crossing arm located at right front corner of the chassis (the front bumper), and when opened, this arm shall extend in a line parallel to the body side and aligned with the right front wheel.

5.35.2 The pedestrian-student safety-crossing arm shall automatically open to its fully extended position whenever the school bus stop arm is activated, and the crossing arm shall return to its park position when the stop arm is deactivated.

5.35.3 The crossing arm shall extend at least 1780 mm (measured from the assembly pivot point) when in the extended position, the crossing arm shall not extend past the end of the bumper when in the stowed position.

5.35.4 All components of the crossing control arm and all connections shall be weatherproofed.

5.35.5 The crossing control arm shall incorporate system connectors (electrical or air) at the gate and shall be easily removable to allow for towing of the bus.

5.35.6 The crossing control arm shall be constructed of non-corrodible or nonferrous material or shall be treated in accordance with the body sheet metal specification.

5.35.7 There shall be no sharp edges or projections that could cause injury or be a hazard to students and the end of the arm shall be rounded.

5.35.8 An automatic recycling interrupt switch may be installed for temporarily disabling the crossing control arm.

5.35.9 The assembly shall include a device attached to the bumper near the end of the arm to automatically retain the arm while in the stowed position and that device shall not interfere with normal operations of the crossing control arm.

5.36 Sun shield

5.36.1 The school on Type A buses, the sun shield (visor) shall be installed by the chassis manufacturer.

5.36.2 The school on Type B, C, and D buses shall be equipped with an interior adjustable sun shield and install in a position convenient for use by the driver, as following:

- a) The sun shield shall be tinted at 92 to 95% to allow 5 to 8% light transparency.
- b) The viewing area shall not be less than 140 × 750 mm and shall be adequately supported to prevent excessive vibration.

Note: If additional sunshields are installed, they too shall meet the transparency and securement requirements given in this Clause.

5.37 Undercoating

5.37.1 The entire underside of the body, including floor sections, cross-members, and below-floor-line side panels, shall be coated with rust-proofing material meet all performance requirements of according to Standard⁽¹⁰⁾

5.37.2 The undercoating compound shall be applied with suitable airless or conventional spray equipment to the undercoating material manufacturer recommended film thickness and shall show no evidence of voids in the cured film.

5.37.3 The undercoating material shall not cover any exhaust components of the chassis.

5.38 Ventilation

5.38.1 The school bus shall be equipped with a suitably controlled ventilation system of sufficient capacity to supply an adequate quantity of air under operating conditions without the windows being opened (except in extremely warm weather).

5.38.2 Fan(s) shall be placed in a location where they can be adjusted for maximum effectiveness and where they do not obstruct the driver's vision to the mirrors or interfere with the safe operation of the vehicle.

- a) Fans shall have 152 mm (nominal) diameter.
- b) Fan blades shall be enclosed in a protective cage .
- c) Each fan shall be controlled by a separate switch.

5.38.3 All school buses shall be equipped with at least one static-type exhaust vent in a low-pressure area of the body.

5.38.4 Roof hatches designed to provide ventilation in all types of exterior weather conditions may be provided.

5.38.5 Circulation fans that supply additional air to the windshield may be used, and shall be located forward of the driver.

Note: Circulation fans shall not be used in lieu of the defroster system

5.39 Wheel housing

5.39.1 Wheel housing openings shall allow easy tire removal.

5.39.2 Wheel housing shall be constructed of sheet steel with a minimum thickness of 1.6 mm or another material of equivalent strength and shall be attached to the floor sheets in a manner that prevents dust or water from entering the body.

⁽¹⁰⁾ Follow the standard SAE J1959 until the Saudi standard is adopted

5.39.3 Any portion of a raised wheel housing shall not extend into an emergency door opening or into an aisle leading to an emergency door.

5.39.4 The inside height of wheel housing above the floor line shall not exceed 300 mm.

5.39.5 Type A2, B, C, and D buses

In addition to meeting the requirements of Clause 5.39.1 to 5.39.4, the wheel housing shall provide clearance for chains on dual wheels according to Stanarad⁽¹¹⁾.

5.40 Windshield and windows

5.40.1 General

5.40.1.1 All school buses shall be provided with laminated safety glass on windscreens and other windows according to Saudi Standard SASO GSO 1677 when tested in accordance with SASO ISO 3537, SASO ISO 3538, SASO ISO 3917 and SASO ISO 13837.

5.40.1.2 The windshield and all windows safety glass shall be transparent and free from any distortions that obscure the visibility of the driver.

5.40.1.3 The windshield and all windows safety glass shall not be affected by the atmospheric conditions, chemicals and heat.

5.40.1.4 The rear window safety glass shall be provided with suitable anti fog system.

5.40.1.5 The side windows for the passenger compartment, except service or emergency door windows, shall be of the vertical sliding split-sash type.

5.40.1.6 The maximum area of the opening side windows in the body structure shall be 7100 cm².

5.40.1.7 The driver's window (if installed by the body manufacturer) shall be made of double-paned hermetically sealed safety glass with an insulating air space.

5.40.1.8 The luminous transmittance of the all windows and windshield shall be not less than 70%.

5.40.2 Each side window safety glass shall provide an unobstructed opening of at least 230 mm high but not more than 330 mm high and at least 558 mm wide, obtained by lowering the window.

Note: One window on each side of the bus may be less than 558 mm wide.

5.40.3 When a school bus with a gross vehicle weight rating (GVWR) of 4,500 kg or less is tested according to SASO GSO 36 at 48 km/h impacts a fixed collision barrier that is perpendicular to the line of travel of the vehicle, the windshield mounting of the vehicle shall retain not less than the minimum portion of the windshield periphery 50 % as shown in Saudi Standard SASO GSO 40. (FMVSS 571.212)

⁽¹¹⁾ Follow the standard SAE J683 until the Saudi standard is adopted

5.41 Electrical components**5.41.1 Wiring (Chassis)**

5.41.1.1 Materials in all electrical components shall contain no mercury.

5.41.1.2 All wiring shall use color and at least one other method for identification and the other method shall be either a number code or name code.

5.41.1.3 Incomplete school bus

a) The chassis manufacturer of an incomplete vehicle shall install a readily accessible terminal strip or connector on the body side of the cowl or in an accessible location in the engine compartment of vehicles designed without a cowl .

b) The strip or connector shall contain the following terminals for the body connections:

1) Main 100-amp body circuit;

2) Tail lamps;

3) Right turn signal;

4) Left turn signal;

5) Stop lamps;

6) Back-up lamps; and

7) Instrument panel lamps (controlled by dimmer switch).

5.41.1.4 An appropriate identifying diagram (color plus a name or number code) for all chassis electrical circuits shall be provided to the body manufacturer for distribution to the end user.

5.41.1.5 Wiring for the headlamp system must be separate from the electronic controlled body solenoid/module.

5.41.2 Wiring (Body)

5.41.2.1 All wiring shall conform to current applicable SAE recommended practices.

5.41.2.2 All wiring shall have an amperage capacity exceeding the design load by at least 25%.

5.41.2.3 A body wiring diagram, sized to be easily read, shall be furnished with each bus body or affixed to an area convenient to the electrical accessory control panel.

5.41.2.4 The body power wire shall be attached to a special terminal on the chassis.

5.41.2.5 Each wire passing through metal openings shall be protected by a grommet.

5.41.2.6 Wires not enclosed within the body shall be fastened securely at intervals of not more than 455 mm.

5.41.2.7 Wiring shall be arranged in circuits, as required, with each circuit protected by a fuse breaker or electronic protection device.

5.41.2.8 A system of color and number-coding shall be used and an appropriate identifying diagram shall be provided to the end user, along with the wiring diagram provided by the chassis manufacturer.

5.41.2.9 Chassis wiring diagrams shall be supplied to the end user in owner manual (Operating Instructions).

5.41.2.10 The following body interconnecting circuits shall be color-coded, as noted:

Function	Color
Left-Rear Directional Lamp	Yellow
Right-Rear Directional Lamp	Dark Green
Stop Lamps	Red
Back-up Lamps	Blue
Tail Lamps	Brown
Ground	White
Ignition Feed, Primary Feed	Black

5.41.2.11 The color of the cables shall correspond to Standard⁽¹²⁾.

5.41.2.12 Wiring shall be arranged in at least six regular circuits, as follows:

- a) Head, tail, stop (brake), clearance and instrument panel lamps;
- b) Step well lamps shall be actuated when the entrance door is open;
- c) Dome lamps;
- d) Ignition and emergency door signal;
- e) Turn signal lamps; and
- f) Alternately flashing signal lamps.

5.41.2.13 Any of the above combination circuits may be subdivided into additional independent circuits.

5.41.2.14 Defrosters shall be wired on an independent circuit:

5.41.2.15 Whenever possible, all other electrical functions (such as sanders and electric type windshield wipers) shall be provided with independent and properly protected circuits.

5.41.2.16 Each body circuit shall be coded by number or letter on a diagram of circuits and shall be attached to the body in a readily accessible location.

5.41.3 Buses may be equipped with a 12-volt power port in the driver's area.

5.41.4 The entire electrical system of the body shall be designed for the same voltage as the chassis on which the body is mounted.

5.42 Side intrusion

The school bus body shall be constructed to withstand an intrusion force equal to the curb weight of the vehicle or 88.9 kN, whichever is less.

Note: Each vehicle shall be capable of meeting this requirement when tested in accordance with the test procedure specified in Annex (B).

5.43 Speedometer and odometer devices

5.43.1 Speedometer

5.43.1.1 Each school bus shall be provided with a speedometer located within the direct field of view of the driver in the dashboard so that it can be easily observed and shall be clearly legible both day and night.

5.43.1.2 The speedometer shall be marked in kilometres per hour (km/h).

5.43.1.3 The speedometers intended for school buses shall be graduated with 1, 2, 5 or 10 km/h., and the numerical speed values shall be indicated at intervals not exceeding 20 km/h.

⁽¹²⁾ Follow the standard SAE J1128 until the Saudi standard is adopted

5.43.2 Odometer

5.43.2.1 Each school bus shall be provided with an odometer in a suitable place in the dashboard so that the driver can easily see it.

5.43.2.2 The odometer shall be marked in kilometres (km).

5.43.2.3 The odometer intended for school buses shall be displayed an integer number composed of a minimum of 6 digits.

5.43.3 Speedometer and odometer devices shall meet technical requirements and test methods according to **Standard SASO/FDS 31835 “Road vehicles - Speedometer and odometer devices”**.

5.44 Controls, telltales and indicators devices

5.44.1 The controls shall be available in order for them to be operated by the driver.

5.44.2 The tell-tales and indicators and their identification shall be located so that they are clearly visible to the driver when operating during the day and night.

5.44.3 Each school bus shall be equipped with the controls, telltales and indicators as following:

- 1) Master lighting switch;
- 2) Headlamp passing beams;
- 3) Headlamp high beams;
- 4) Headlamp cleaning;
- 5) Turn signal indicator;
- 6) Hazard warning signal;
- 7) Rear fog lamp;
- 8) Fuel level;
- 9) Engine oil pressure;
- 10) Engine coolant temperature;
- 11) Electrical charging condition;
- 12) Windscreen washing system;
- 13) Windscreen washing and wiping system;
- 14) Windscreen defrosting and defogging system;
- 15) Rear window defrosting and defogging system;
- 16) Position, side marker;
- 17) Safety belt reminder;
- 18) Airbag;
- 19) Antilock brake system;
- 20) Speedometer;
- 21) Odometer;
- 22) Parking brake;
- 23) Horn;
- 24) Engine on-board diagnostics;
- 25) Air conditioning system;
- 26) Heating system;
- 27) Low tyre pressure;
- 28) Electronic stability control; and
- 29) Automatic transmission control position.

5.44.4 Each school bus shall meet the location, identification, color, and illumination requirements in **Standard SASO/FDS 31836 “Road vehicles - Controls, telltales and indicators”** (ECE 121:2015 & FMVSS 571.101)

5.44.5 The identifications of control, indicator, and telltale shall be placed on or near them to identify the control, indicator, and telltale.

5.44.6 Air system pressure gauge

Vehicles equipped with air ride suspension shall be supplied with an air system pressure gauge.

5.45 Vehicle identification number (VIN)

5.45.1 The VIN number shall contain 17 characters and shall comply with the Saudi Standard SASO GSO 1780

5.45.2 The VIN number shall be readable through the vehicle glazing from outside the vehicle adjacent to the left windshield pillar of the light duty vehicles and shall comply with the Saudi Standard SASO GSO 1782

5.45.3 The characters of the VIN number shall in all cases be legible, durable and not easily altered.

5.46 Speed limiters

Each school bus shall be provided with a means of limiting the maximum speed so that its speed does not exceed 80 km/h, and shall meet the technical requirements according to Saudi Standard SASO GSO 1625 when tested in accordance SASO GSO 1626.

5.47 Air bags

5.47.1 The air bag shall be located in suitable position to assist in preventing the driver’s head and chest from impacting the steering wheel or windshield.

5.47.2 The material used to inflate the bag shall not be toxic and cause any irritation.

5.47.3 School buses with GVW less than 3500 kg shall be provided with air bags to the driver and front passenger outboard seat.

5.47.4 School buses carrying 22 passengers and less shall be provided with air bags to the driver side and the front passenger.

5.48 Transmission, starter interlock, and transmission braking effect

5.48.1 Each school bus shall be provided with a transmission, starter interlock, and transmission braking effect that meet the technical requirements according to **Standard SASO/FDS 31840 “Road vehicles - Transmission shift position sequence, starter interlock, and transmission braking effect”** (FMVSS 571.102)

5.48.2 Automatic transmissions shall have no fewer than three forward speeds and one reverse speed.

5.48.3 Mechanical shift selectors shall provide a detent between each gear position when the gear selector quadrant and shift selector are not steering-column mounted.

5.48.4 Automatic transmissions shall have a transmission shifter interlock controlled by the application of the service brake to prohibit accidental engagement of the transmission.

5.48.5 The force required to operate the throttle shall not exceed 7 kg throughout the full range of accelerator pedal travel.

5.49 Air cleaner

5.49.1 A dry element air cleaner shall be provided.

5.49.2 All diesel engine air filters shall include a latch-type restriction indicator that retains the maximum restriction developed during operation of the engine, and the indicator should include a reset control so the indicator can be returned to zero when desired.

5.50 Suspension systems

5.50.1 The capacity of springs or suspension assemblies shall be commensurate with the chassis manufacturer's GVWR.

5.50.2 Rear leaf springs shall be of a progressive rate or multi-stage design .

5.50.3 Front leaf springs shall have a stationary eye at one end and shall be protected by a wrapped leaf, in addition to the main leaf.

5.51 Towing attachment points

5.51.1 Each school bus shall be provided with a front and rear towing devices (i.e., tow hooks, tow eyes, or other designated towing attachment points) to assist in the retrieval of buses that are stuck and/or for towing buses when a wrecker with a "wheel lift" or an "axle lift" is not available or cannot be applied to the towed vehicle.

5.51.2 Towing devices shall be attached to the chassis frame either by the chassis manufacturer or in accordance with the chassis manufacturer's specifications.

5.51.3 Each towing device shall have a strength rating of 13,500 pounds each, for a combined rating of 27,000 pounds with the force applied in the rearward direction, parallel to the ground, and parallel to the longitudinal axis of the chassis frame rail.

5.51.4 For pulling and lifting purposes, tow hooks are meant to be used simultaneously.

5.51.5 The towing devices shall be mounted such that they do not project forward of the front bumper or rearward of the rear bumper.

Note: Type A buses are exempt from the requirement for front tow hooks or eyes due to built-in crush zones.

5.52 Hinges

All exterior metal door hinges shall be designed to allow lubrication to be channeled to the center 75% of each hinge loop without disassembly, unless they are constructed of stainless steel, brass or non-metallic hinge pins or other designs that prevent corrosion.

5.53 Accelerator control

The maximum time to return of a school bus throttle to the idle position when the driver removes the actuating force from the accelerator control, or in the event of a severance or disconnection in the accelerator control system as shown in **Standard SASO/FDS 31838 "Road vehicles - Accelerator control systems"** (FMVSS 571.124), as following:

- a) 1 second for vehicles of 4536 kilograms or less gross vehicle weight rating (GVWR); and
- b) 2 seconds for vehicles of more than 4536 kilograms gross vehicle weight rating (GVWR).

5.54 Passenger compartment air conditioning**5.54.1 General**

5.54.1.1 Each school bus shall be equipped with air conditioning.

5.54.1.2 Evaporator cases, lines and ducting (as equipped) shall be designed in such a manner that all condensation is effectively drained to the exterior of the bus below the floor level under all conditions of vehicle movement and without leakage on any interior portion of the bus.

5.54.1.3 Evaporators and ducting systems shall be designed and installed to be free of projections or sharp edges.

5.54.1.4 On school buses equipped with Type-2 seatbelts having anchorages above the windows, the ducting (if used) shall be placed at a height sufficient to not obstruct occupant securement anchorages.

5.54.1.5 The body may be equipped with insulation, including sidewalls, roof, firewall, rear, inside body bows and plywood or composite floor insulation to reduce thermal transfer.

5.54.1.6 Electrical generating capacity shall be provided to accommodate the additional electrical demands imposed by the air conditioning system.

5.54.1.7 Roofs may be painted white to aid in heat dissipation

5.54.1.8 Air intake for any evaporator assembly(ies), except for front evaporator of Type A-1, shall be equipped with replaceable air filter(s) accessible without disassembly of evaporator case.

5.54.1.9 For all buses (except Type D rear engine transit) equipped with a rear evaporator assembly, evaporator shall not encroach upon head impact zone, but may occupy an area of less than 673 mm from the rear wall and 355 mm from the ceiling.

5.54.1.10 For Type D rear engine transit buses equipped with a rear evaporator over the davenport, the evaporator assembly may not interfere with rear exit window and may not extend above the rear seating row.

5.54.2 Performance

The installed air conditioning system shall cool the interior of the bus from 20 to 37 C, under the test conditions specified in the item 5.54.3.1, and measured at three points (minimum) located 1.2 m above the floor on the longitudinal centerline of the bus as following:

- 1) One m above the center point of the horizontal driver seat surface,
- 2) At the longitudinal midpoint of the body, and
- 3) One m forward of the rear emergency door or, for Type D rear-engine buses, One m forward of the end of the aisle.

Note: for the Type A vehicles placement of the rear thermocouple should be centered in the bus over the rear axle.

5.54.3 Test Conditions**5.54.3.1 The following conditions apply to test:**

- 1) Placing the bus in a room (such as a paint booth) where ambient temperature can be maintained at 37 C;
- 2) heat-soaking the bus at 37 C at a point measured two feet horizontally from the top of the windows on both sides of the bus, with windows open for two hours; and
- 3) closing windows, turning on the air conditioner with the engine running at 1250 ± 50 RPM, and cooling the interior of the bus to 26 C, (standard performance) or 20 C (high performance), within 30 minutes while maintaining 37 C outside temperature.

5.54.3.2 The manufacturer shall provide test results that show compliance with standard systems.

5.55 Exterior noise level

5.55.1 Each school bus shall be constructed so that the noise level does not exceed 85 dBA when measured by the two methods described in GSO technical regulation according to Saudi Standard SASO GSO 1624 when the bus is moving or stationary.

5.55.2 The vehicle, its engine and its noise reduction system shall be so designed, constructed and assembled as to enable the vehicle, in normal use, despite the vibration to which it may be subjected, to comply with the provisions of this requirements.

5.55.3 The noise reduction system shall be so designed, constructed and assembled as to be able to reasonably resist the corrosive action to which it is exposed having regard to the conditions of use of the vehicle and the environmental conditions prevailing.

5.56 Limits of gaseous pollutants

5.56.1 Light-duty unleaded gasoline engines

5.56.1.1 All school buses with a gross vehicle weight (GVW) of 3500 or less kg shall meet the allowable limits of gaseous pollutants and particle mass emitted to the atmosphere according to Saudi Standard SASO GSO 1680 when tested in accordance SASO GSO 1681, SASO GSO 1682, SASO GSO 1683, SASO GSO 1684 and SASO GSO 1685.

5.56.1.2 There shall be no gases emission from the crankcase of the school bus to the atmosphere.

5.56.1.3 The evaporative emission emitted from the fuel system shall not exceed 2.0 grams/test.

5.56.2 Light-duty diesel engines

5.56.2.1 All school buses with a gross vehicle weight (GVW) of 3500 or less kg shall meet the allowable limits of gaseous pollutants and smoke emitted to the atmosphere according to Saudi Standard SASO GSO 1040 when tested in accordance SASO GSO 1041 and SASO GSO 1042.

5.56.2.2 There shall be no gases emission from the crankcase of the school bus to the atmosphere.

5.56.3 Heavy-duty diesel engines

5.56.3.1 All school buses provided with Heavy-duty diesel engines shall meet the allowable limits of gaseous pollutants and smoke emitted to the atmosphere according to Saudi Standard SASO GSO 144 when tested in accordance SASO GSO 145 and SASO GSO 146.

5.56.3.2 The use of defeat device and irrational emissions control strategy is not allowed.

5.56.4 Heavy-duty gasoline engines

5.56.4.1 All school buses provided with Heavy-duty gasoline engines shall meet the exhaust emission requirements according to ECE regulations and/or FMVSS regulations in order for SASO/GSO technical regulations to be approved regarding SASO/GSO the allowable limits of gaseous pollutants and particle mass emitted to the atmosphere from heavy-duty gasoline engines.

5.56.4.2 The carbon monoxide in the exhaust gases at idle speed shall not exceed 3.5% by volume.

5.56.4.3 There shall be no gases emission from the crankcase of the school bus to the atmosphere.

6- Safety equipment's

6.1 General

6.1.1 Each school bus shall be provided with the tools necessary to dismantle and install the wheels so that they are suitable for use according to the type of bus and include the lifting machine (jack); its lever and wheel spanner.

6.1.2 Each school bus shall be provided with a fire extinguisher and a first aid kit shall be located within 2 m of center of the top of the driver's seat cushion, regardless of location of the driver's seat.

6.1.3 The mechanism for accessing and releasing safety equipment shall not require the removal or adjustment of any unrelated object.

6.1.4 Each school bus shall be provided with two reflector triangles for use in emergency situations and in accordance with Standard⁽¹³⁾.

6.1.5 Each school bus shall be provided with tyre pressure gauge.

6.2 Fire extinguisher

6.2.1 All school buses shall be equipped with at least one portable fire extinguisher from dry chemical and a rating of at least 2-A:10B-C according to Saudi Standard SASO GSO ISO 7165 "Firefighting -- Portable fire extinguishers -- Performance and construction"

6.2.2 The portable fire extinguisher shall be equipped with a pressure gauge and shall be mounted in a location that is readily accessible to the driver.

Note: If the fire extinguisher is not in view (e.g., in an enclosed compartment), its location shall be clearly marked.

6.3 First aid kit

6.3.1 All school buses shall be provided with first aid kit made of metal or plastic of comparable strength at a suitable location and shall be mounted in a location that is readily accessible to the driver.

Note: If the first aid is not in view (e.g., in an enclosed compartment), its location shall be clearly marked.

6.3.2 The first aid kit shall contain at least the following items:

- a) one first aid pocket guide;
- b) one record book;
- c) four pairs of non-latex gloves;
- d) 150 individually wrapped 25 × 75 mm adhesive dressings;
- e) eight 50 mm compress dressings; f) six 100 mm compress dressings; g) two gauze eye pads;
- h) one eye shield;
- i) three four-ply gauze dressings, a minimum of 914 × 914 mm in size;
- j) two 50 mm × 5.5 m gauze bandages;
- k) one packet of 25 mm × 4.6 m adhesive tape;
- l) six triangular bandages;
- m) one 70 × 610 mm rolled metal splint;
- n) one pair of sliver tweezers;
- o) one pair of 15 cm scissors; and
- p) twelve 50 mm safety pins.

⁽¹³⁾ Follow the standard 49 CFR 571.125 or ECE 27 until the Saudi standard is adopted.

7- Information of vehicle

7.1 The manufacturer shall be mounted a conformity label to the edge or latch post on the driver's door of each school buses.

7.2 The conformity label shall meet the following requirements:

7.2.1 It shall be made of material resistant to deterioration.

7.2.2 It shall be permanently affixed in a manner that that is difficult to remove without damaging it.

7.2.3 It shall be shown the information in both Arabic and English languages, and the height of the letters shall not be less than 2.4 mm, and be in a clearly legible manner can be read easily:

7.2.3.1 Name of manufacturer and country of manufacture (or assemble).

7.2.3.2 Year and month of production.

7.2.3.3 Maximum gross vehicle weight (GVW) in kilograms.

7.2.3.4 Maximum gross axle weight rating (GAWR) for each axle, in kilograms.

7.2.3.5 Designation the recommended tire size from the vehicle's manufacturer.

7.2.3.6 Number of passengers.

7.2.3.7 Weight of the passenger load.

7.2.3.8 The statement "This school buses complies with all Saudi standard for vehicles that were issued up to the date of manufacture".

7.3 If the school bus is equipped with a navigation system, all geographic data and maps shall be in Arabic with the ability to convert them into English (Arabic & English), and the voice guidance systems shall be in Arabic with the ability to convert it into English (Arabic & English).

7.4 An All instructions indicated on the driver's monitor/display shall be available in Arabic and English

8- Owner's manual (Operating Instructions)

Each school bus shall be equipped with Owner's manual in Arabic and English including the following information:

8.1 The technical specifications of the school bus.

8.2 Instructions relating to the operation of the school bus.

8.3 Instructions relating to the periodic maintenance.

8.4 Technical instructions about the recommended tyre designation, indicating inflation pressure and replacement method.

8.5 The maximum speed limit, maximum torque and maximum power at rpm.

9 - Identification

9.1 Each school bus shall be provided with the following stickers:

9.1.1 The word "SCHOOL BUS" shall be displayed in both Arabic and English on the front and back of the bus, and its letters are in black color.

The letters shall meet the following requirements:

a) It shall be at least 200 mm high, with a minimum stroke width of 32 mm.

b) It shall be placed as high as possible without reducing its visibility.

c) It shall be placed above the windshield and rear window and not more than 25 off the vertical.

d) It shall be in approximately the same horizontal plane as the red signal lamps and within 200 mm of the vertical plane of the warning lamps.

9.1.2 The words "DO NOT PASS WHEN RED LIGHTS FLASHING" shall be displayed in both Arabic and English on the rear of the bus, and its letters are in black color.

The letters shall meet the following requirements:

a) the lettering shall be at least 75 mm, but not more than 125 mm, high; and

b) the stroke width of the lettering shall be at least one-sixth the height of the letters.

9.1.3 The type of fuel used by the school bus shall be indicated on the body, immediately in 25 mm lettering adjacent to the filler pipe.

9.1.4 The words "DO NOT PARK WITHIN 3 M OF THIS SIDE" shall be displayed in both Arabic and English on the mobility aid entrance as a warning poster, and its letters are in black color, and the letter height shall not be less than 25 mm.

9.1.5 The words "CAUTION – STAND CLEAR" shall be displayed in both Arabic and English on the mobility aid entrance as a warning poster, and its letters are in black color, and the letter height shall not be less than 25 mm.

9.1.6 The word "BATTERIES" shall be indicated on the battery compartment door in 50 mm lettering;

10- School bus requirements for persons with special health care needs**10.1 General**

School buses equipped with wheelchair accessible shall meet the requirements of Clauses 4 to 9, in addition to the following requirements:

10.2 International symbol of wheelchair

The international symbol of wheelchair (see Figure (2)) shall meet the following requirements:

- a) Minimum size of 100 x 100 mm.
- b) Placed on the exterior front and rear of the bus in a location that is visible to traffic.

10.3 Mobility aid entrance**10.3.1 Location**

10.3.1.1 An accessible bus mobility aid entrance shall be located on the right side of the bus.

10.3.1.2 The mobility aid entrance shall be located immediately rearward of the service entrance door.

10.3.2 Width and height

- a) The mobility aid entrance shall be equipped with an installed lift.
- b) A minimum of 760 mm width and 1400 mm height shall be the clear opening of a mobility aid entrance.

10.3.3 Automated illumination

School buses shall be equipped with a light, which automatically operates when the mobility aid entrance open. The light shall illuminate the lift platform.

10.4 Emergency exit door

10.4.1 School buses equipped with mobility aid entrance shall have emergency door exits located on a different wall of the bus than the mobility aid entrance.

10.4.2 The emergency exit door shall have a minimum width of 760 mm.

10.5 Aisle width

The aisle width of all school buses equipped to accommodate a mobility aid shall have a minimum of 760 mm between fixed vehicle structures leading from any mobility aid position to at least one emergency exit door.

10.6 Mobility aids**10.6.1 Space requirements****10.6.1.1 Floor space**

- a) The minimum floor space requirements for each mobility aid shall be 685 x 1220 mm.
- b) The 1220 mm length shall be parallel to the vehicle's longitudinal centerline (see Figure (3)).
- c) A maximum overlap of 150 mm of mobility aid positions or ambulatory seating in the longitudinal direction may be used.

10.6.1.2 Fixed vehicle structures

There shall be no fixed structures within a mobility aid positions, except for mobility aid securement and occupant restraint system (MASOR), school bus seats, or school bus barriers within the clear zone shown in Figure (4).

10.6.2 Securement

10.6.2.1 Securement devices

All mobility aid devices shall meet the requirements of Standard⁽¹⁴⁾.

10.6.2.2 Securement anchorage points

The anchorage points for the mobility aid securement system shall be separated from each other by a minimum center-to-center distance of 350 mm as shown in Figure (3) and shall withstand a forward and rearward static loading of 15.7 kN applied in accordance with Figure (5).

Note: The applied load of 15.7 kN is compatible with Standard⁽¹⁵⁾ (substituting for the seat a mobility aid having a minimum test mass of 80 kg).

10.6.3 Mobility aid occupant restraint

10.6.3.1 Seat belts

- a) A type 2 seat belt assembly shall be provided at each outboard mobility aid position.
- b) A type 1 and 2 seat belt assembly shall be provided at each inboard mobility aid position.
- c) All seat belt assemblies shall meet the technical requirements of Standard⁽¹⁶⁾.
- d) Type 2 occupant restraint systems shall meet the requirements of Standard⁽¹⁴⁾.

Note:

- a) See Standard⁽¹⁶⁾ of the MVSR for definitions type 1 and 2 seat belt assemblies.
- b) Scooter-type mobility aids should be transported only in a position where a type 2 seat belt is provided.

10.6.3.2 Occupant restraint anchorage points

- a) Anchorage points in an occupant restraint system shall meet the strength requirements of Standard⁽¹⁷⁾.
- b) The upper torso anchorage points shall be located within the zone shown in Figure (6).

10.6.4 Simultaneous loading

If a mobility aid securement and occupant restraint systems share common anchorage points, the loading requirements of Clauses 10.6.2.2 and 10.6.3.2 shall be met simultaneously.

10.7 Lifts

Vehicle lifts and installations shall comply with the requirements of Standards Standard⁽¹⁸⁾.

⁽¹⁴⁾ Follow the standard CAN/CSA-Z605 or equivalent until the Saudi standard is adopted.

⁽¹⁵⁾ Follow the standard FMVSS 207 until the Saudi standard is adopted.

⁽¹⁶⁾ Follow the standard FMVSS 209 until the Saudi standard is adopted.

⁽¹⁷⁾ Follow the standard FMVSS 210 until the Saudi standard is adopted.

⁽¹⁸⁾ Follow the standard FMVSS 403 & 404 or equivalent until the Saudi standard is adopted.

10.8 Caution labels for entrances and lifts**10.8.1 Caution label for the mobility aid entrance**

The following wording shall appear adjacent to or on the mobility aid entrance in Arabic and English:

DO NOT PARK WITHIN 3 M OF THIS SIDE & (ممنوع الوقوف ضمن حدود 3 أمتار)

10.8.2 Caution label for the lift

The following wording shall appear adjacent or on the lift in Arabic and English:

CAUTION – STAND CLEAR & (تنبيه – قف بعيداً)

The cautionary notice shall be clearly visible when viewing the vehicle from outside, in the general proximity of the lift entrance.

10.8.3 Appearance

The lettering in the labels specified in Clauses 10.8.1 and 10.8.2 shall be

- a) At least 25 mm high.
- b) In a color that contrasts with the background.
- c) Readily visible.

Pictograms in accordance with Standard⁽¹⁹⁾ may be used in conjunction the written labels.

10.9 Seating for ambulatory passengers

On lift-equipped school buses with ambulatory seating, seat frames shall be equipped type 1 or type 2 seat belt assemblies (as defined in Standard⁽¹⁷⁾).

⁽¹⁹⁾ Follow the standard SAE J2402 until the Saudi standard is adopted.



Figure (2) – International symbol of wheelchair

All dimensions are in millimetres (inches)

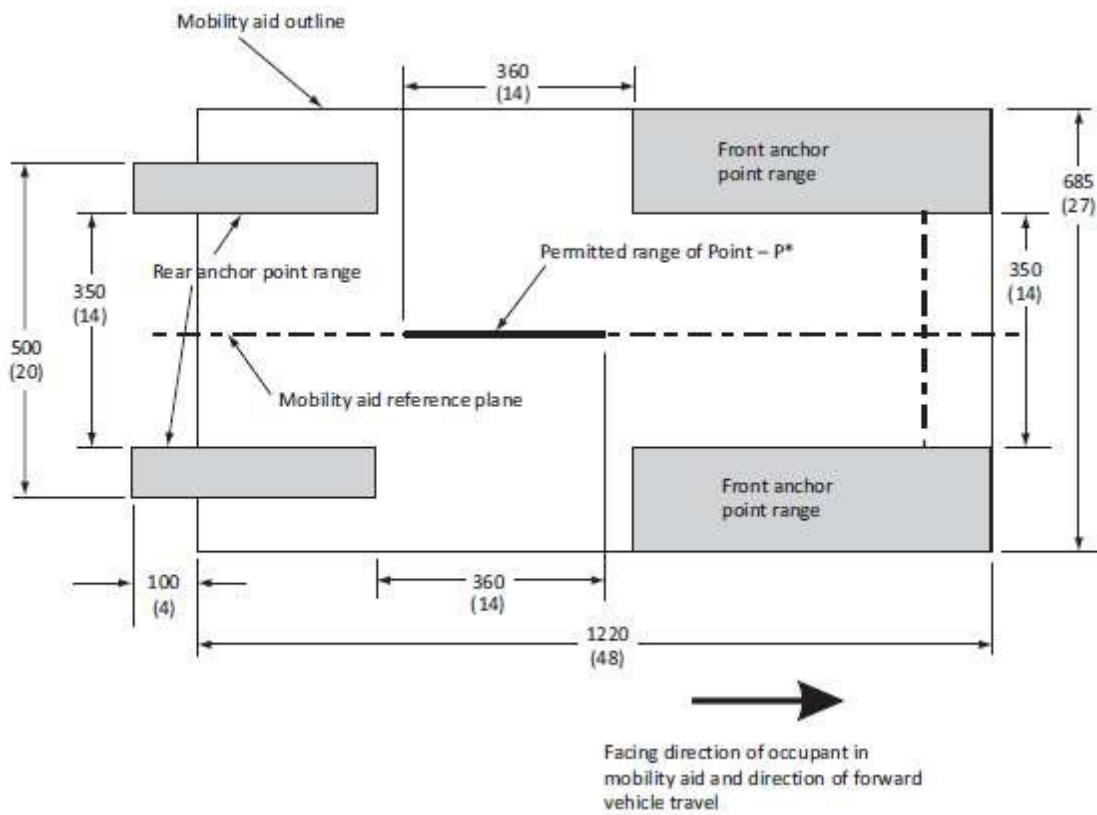

Notes:

1) Anchor zones are located equidistant with respect to the mobility reference plane, e.g., 175 mm either side of the line.

Figure (3) – Top view of the maximum mobility aid outline

All dimensions are in millimetres (inches)

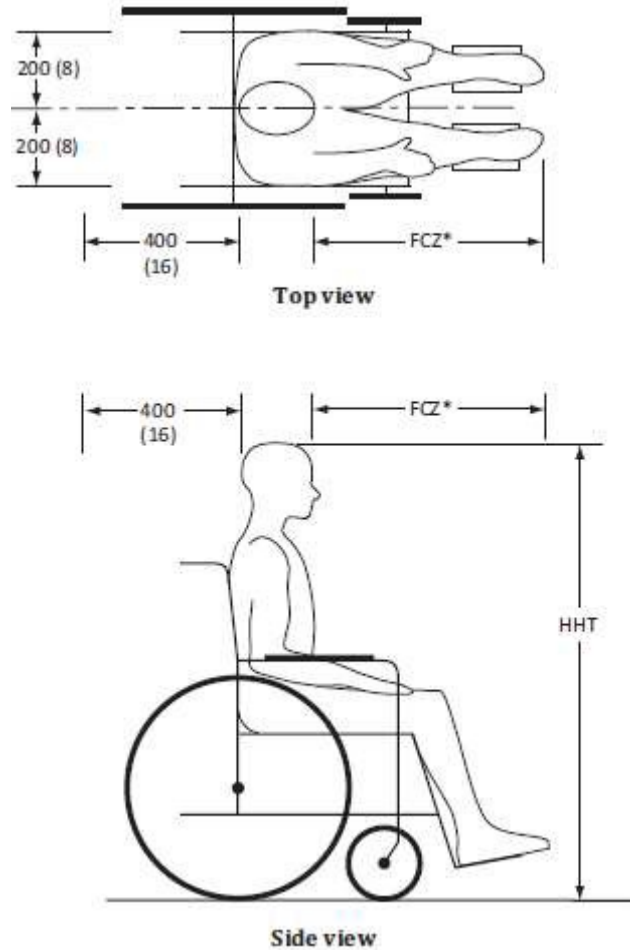

* FCZ (front clear zone) = 650 mm with upper-torso restraint = 950 mm with only pelvic restraint.

Notes:

- 1) The rear clear zone is measured from the rearmost point on an occupant's head.
- 2) The front clear zone is measured from the frontmost point on an occupant's head.
- 3) Seated head height (HHT) ranges from about 1200 mm for a small adult female to about 1550 mm for a tall adult male.
- 4) Both pelvic and upper-torso belts should be used (this is strongly recommended)

Figure (4) – Clear zone around a mobility aid position

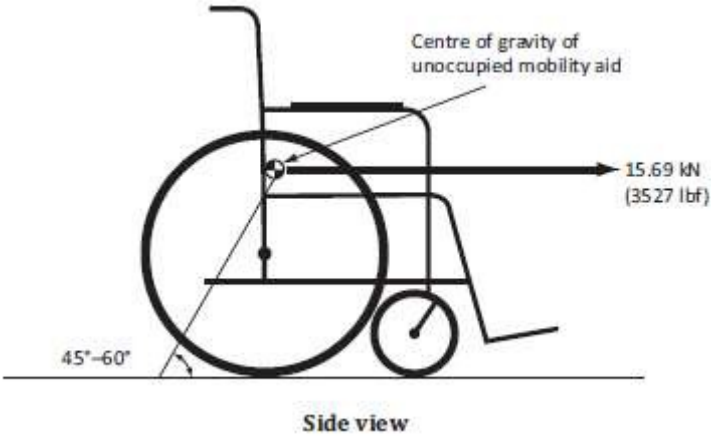
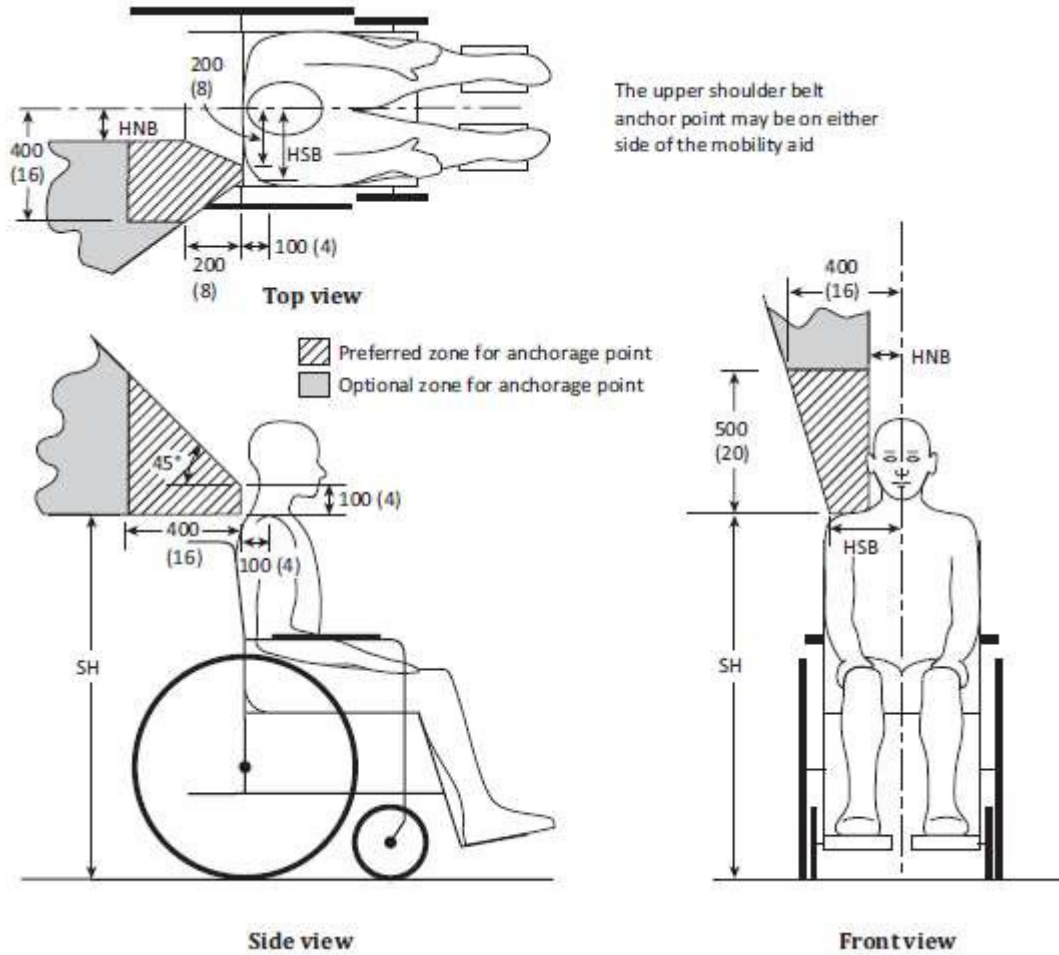

Figure (5) – Loading of anchorage points in a mobility aid securement system

All dimensions are in millimetres (inches)



Notes:

1) *SH* is the shoulder height from the floor.

It is 775 mm for a six-year-old child ATD (anthropometric test dummy), or 1100 mm for a 50th percentile male ATD, seated in a mobility aid.

The front clear zone is measured from the frontmost point on an occupant's head.

2) *NHB* is the half-neck breadth.

It is 50 mm for a six-year-old child ATD, or 75 mm for a 50th percentile male ATD, seated in a mobility aid.

3) *HSB* is the half shoulder breadth.

It is 130 mm for a six-year-old child ATD, or 200 mm for a 50th percentile male ATD, seated in a mobility aid.

Figure (6) – Loading of anchorage points for an upper torso restrain belt

Annex (A)
(Normative)

Roof hatch performance test

A.1 The test shall be conducted under the following conditions:

- a)** The school bus shall be on a flat horizontal surface; and
- b)** The temperature inside and outside shall be maintained between 20 and 30 for 4 h immediately preceding the test and during the test.

A.2 An increasing force shall be applied to the head form shown in figure (A.1) to cause at a velocity of 51 mm/min from a point inside the bus that is at the center of the roof hatch plane in a direction that is outward and perpendicular to the undisturbed surface of the hatch until one of the following occurs:

- a)** the force at the point of application equals 3100 N;
- b)** The roof hatch opens; or
- c)** The inner surface of the hatch at the center has moved perpendicularly to undisturbed surface of the hatch a distance equal to the length of the smallest chord along the surface of the hatch passing through the center divided by 4.

All dimensions are in millimetres (inches)

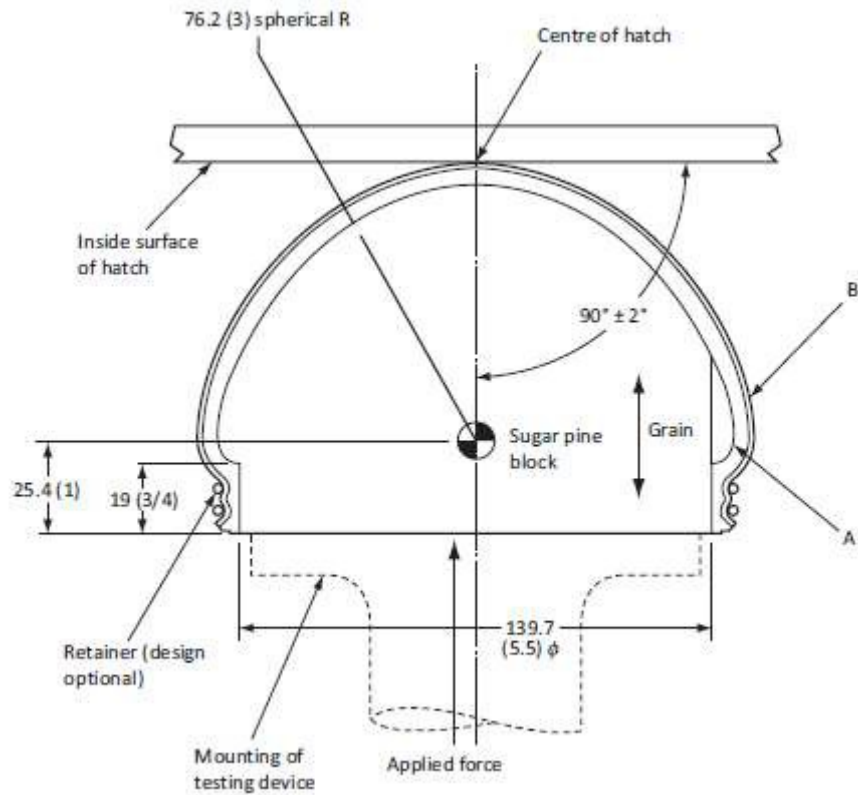

Legend:

A = 6.35 ± 0.63 mm synthetic underlayer, with 1720 ± 170 kPa tensile strength and 50 ± 10 % elongation.

B = Napa goat skin, wet chamois, or 0.76 ± 0.07 mm synthetic skin, all with 6900 ± 350 kPa tensile strength and 100 ± 5 % elongation.

Figure (A.1) – Head-form

Annex (B)
(Normative)

Side Intrusion Test

B.1 Procedures

B.1.1 The complete body structure, or a representative seven-body section mock up with seats installed, shall be load-tested at a location 610 ± 50 mm above the floor line, with a maximum 254 mm diameter cylinder, 1220 mm long, mounted in a horizontal plane.

B.1.2 The cylinder shall be placed as close as practical to the mid-point of the tested structure, spanning two internal vertical structural members.

B.1.3 The cylinder shall be statically loaded to the required force of curb weight or 9090 kg, whichever is less, in a horizontal plane with the load applied from the exterior toward the interior of the test structure.

B.2 Acceptance criteria

B.2.1 When the minimum load has been applied, the penetration of the loading cylinder into the passenger compartment shall not exceed 10 inches from its original point of contact.

B.2.2 There can be no separation of lapped panels or construction joints.

B.2.3 Punctures, tears or breaks in the external panels are acceptable but are not permitted on any adjacent interior panel.

Bibliography

- [1] National congress on school transportation (2015 Edition).
- [2] CAN/CSA-D250-16 "School buses".